



LAND CLEARING Tracked Carriers





5 MAKE THE DIFFERENCE

6 ABOUT FAE

8 VEICOLI CINGOLATI

12 PT200 - *New*

32 PT300

54 PT400 - *New*

76 PT550





MAKE THE **DIFFERENCE**

At FAE, every machine, accessory and optional component is designed with utmost precision, the highest quality materials and the most advanced technology.

Each detail is designed to make the execution of the tasks as quick and efficient as possible and for the specific applications, conditions and environment where it will be carried out.

Every FAE machine and accessory was created to make a difference at work and, given the importance of many of the applications we work on, for the planet. This is why each member of our team, each partner and customer works daily.

ABOUT **FAE**

With a range of over 90 products and 400 models, FAE can meet the most diverse demands for forestry, agricultural, road construction, building and demining applications. The FAE product range includes heads for tractors, excavators, skid steer loaders, special vehicles and tracked vehicles, with cabins or remote controlled. FAE was founded in 1989, and the company's main office is still located in Fondo, Italy. Production, sales, after-sales service and parts services are handled by our 3 production sites, the main office, 7 commercial branches and a network of authorized dealers all over the world.



GLOBAL QUALITY

Our precision design and production processes use advanced technologies to ensure long-term performance and reliability.

CONSTANT INNOVATION

We design unique and cutting-edge products based on customer's specific needs for solutions that pave the way to the future.

COMPLETE PRODUCT LINE

We offer an extensive product range and a high degree of customization to make each process more efficient, more productive, and easier.

TOTAL SUPPORT

We make our vast range of machines, dedicated accessories and components, as well as our technical assistance available worldwide.

LAND CLEARING **TRACKED CARRIERS**

FAE tracked carriers are great for forestry and agricultural work. The many interchangeable heads available make these carriers extraordinarily flexible. FAE PTs are designed and built to work under extreme conditions, with maximum productivity and reliability.





A CIASCUNO IL SUO CINGOLATO

The FAE PT range offers four models, each with a wide selection of specific options to best meet every operational need.



PT200

The compact, powerful tracked carrier.



PT300

The tracked carrier that is ready for anything



PT400

The powerful and versatile tracked vehicle.



PT550

The tracked carrier for big challenges.

MODEL	100 hp	200 hp	300 hp	400 hp	500 hp	550 hp
PT200		188 hp				
PT300			275 - 302 hp			
PT400				380 hp		
PT550					475 - 536 hp	

FAE PT200

THE COMPACT, POWERFUL TRACKED CARRIER.

The FAE PT200 is a tracked carrier designed for forestry work when there is little space to maneuver anywhere that requires superior agility and efficiency. Manage wooded areas, create firebreaks, work near power lines, oil and gas pipelines. The sturdy construction with oscillating undercarriage is the best match for the 140/U/PT mulcher. The exclusive Sonic system increases mulching efficiency to achieve maximum productivity with minimum fuel consumption. The engine power and low operating weight of the CAT C4.4 Acert makes it possible to work on steep slopes and soft ground. The hydraulic system guarantees reliability and efficiency. The spacious cab is unrivaled when it comes to comfort, ergonomics and operator safety.

POWERFUL

The flexibility and reliability of one of the world's most popular four-cylinder engines. The Caterpillar C4.4 Tier 4 Final/Stage V engine delivers 188 hp, with reliably superior performance and a global service network.

NIMBLE

Managing steep, soft, uneven ground with little space to maneuver is normal for FAE PT200. Longitudinal slopes of 45° and transverse slopes of 32°. High power, low operating weight. Minimum pressure against the ground: 0.28 kg/cm².

TECHNOLOGICAL

High-tech body and soul. An integrated system developed by FAE to ensure maximum performance. With a network of sensors to monitor key operating parameters, everything in the PT200 can be easily fine-tuned.

COMFORTABLE

Designed with total operator comfort in mind. ROPS/FOPS/OPS cabs - the industry benchmark. High Lexan™ windows. Ergonomic joysticks. Pneumatic seat. 7" color display to monitor and modify all operating functions.



PRODUCTIVE

PT200 was created with a clear objective in mind: to optimize forestry work. The FAE 140/U/PT mulcher helps you easily manage woods and forests and create firebreaks near electric lines, oil and gas pipelines. The exclusive Sonic system increases mulching efficiency to achieve maximum productivity with minimum fuel consumption.

AN ENGINE THAT'S ALWAYS READY TO GO

You can count on the FAE PT200 engine. The **Caterpillar C4.4 Acert** four-cylinder is a popular engine, highly respected worldwide. Equipped with twin turbochargers with after cooler, Acert technology and Common Rail injection, this engine delivers an impressive 188 hp. Efficient, reliable, with superb consumption/power ratio.

Compliance with the **Tier 4 Final/Stage V** standard is guaranteed with the combination of diesel particulate filter (DPF), selective catalytic reduction (SCR) and diesel oxidation catalyst (DOC) technologies.

A combination that maximizes uptime and requires minimal maintenance over time, achieved by passive regeneration that does not require interrupting the work.

The 4.4-liter displacement and a cooling system designed specifically for the FAE PT200 ensure peak performance in heavy-duty applications and when working in tropical climates.

The simple, uncluttered **internal layout** is synonymous of reliability



Optimized airflow for working in extreme conditions

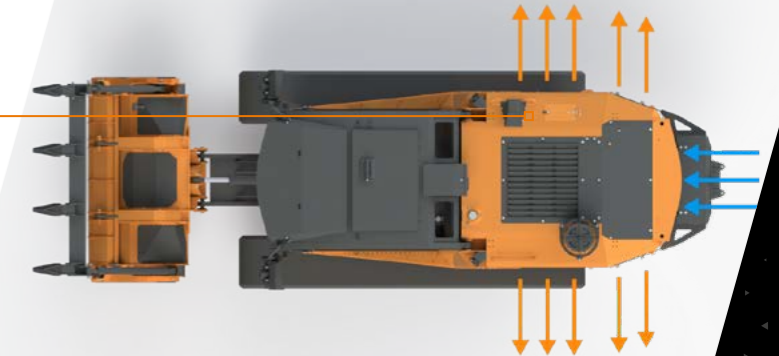

Easy access to **filters** makes maintenance quick and easy



EFFICIENT, RELIABLE TRANSMISSION.

The transmissions designed for the FAE PT200 are based on two fundamental concepts: technology and integration. **Electronically-controlled pumps and sensors and a dedicated control unit**, working together to deliver maximum performance. The systems are designed to enable the CAT C4.4 Acert engine to operate at optimal rpms at all times.

The FAE PT200's **hydrostatic transmission** also serves to dampen operating loads. This ensures that

the carrier and its key components are subjected to less stress, reducing wear and tear. The end result is greater durability than a mechanical transmission.

The FAE PT200's **integrated load control feature** optimizes power management, ensuring that the mulcher always operates at peak power while reducing forward speed as needed.

Diagram of the FAE PT200 **hydrostatic transmission**: simple and effective

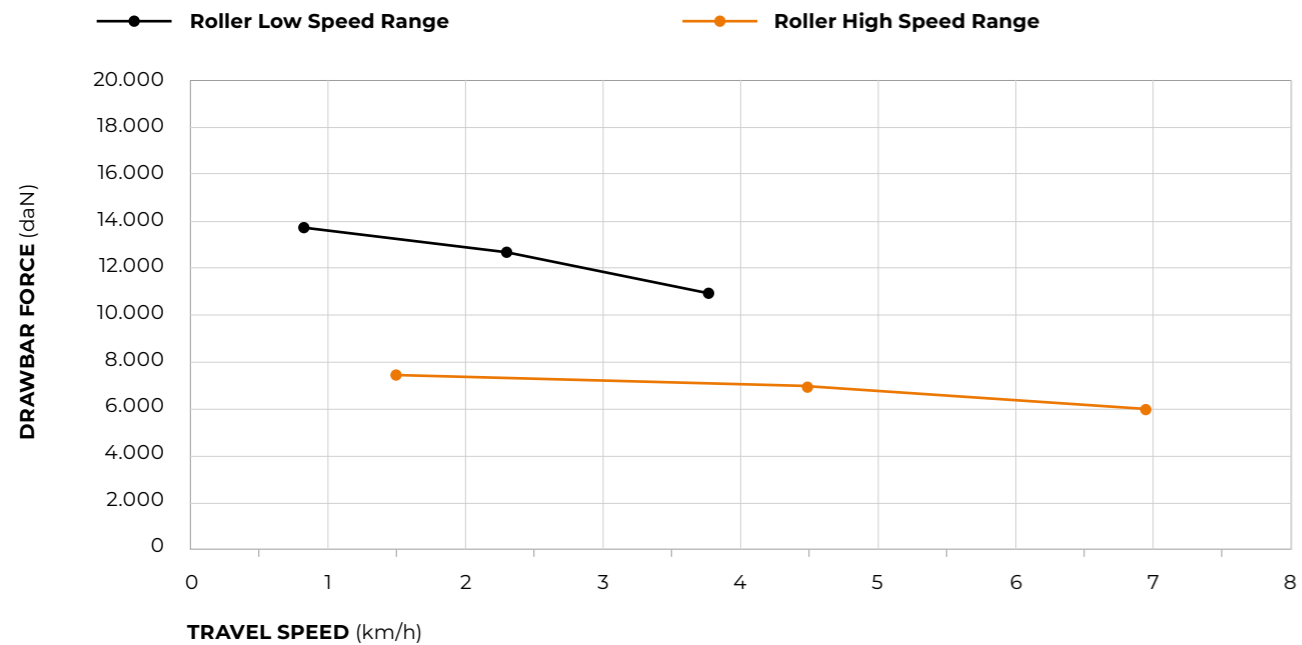
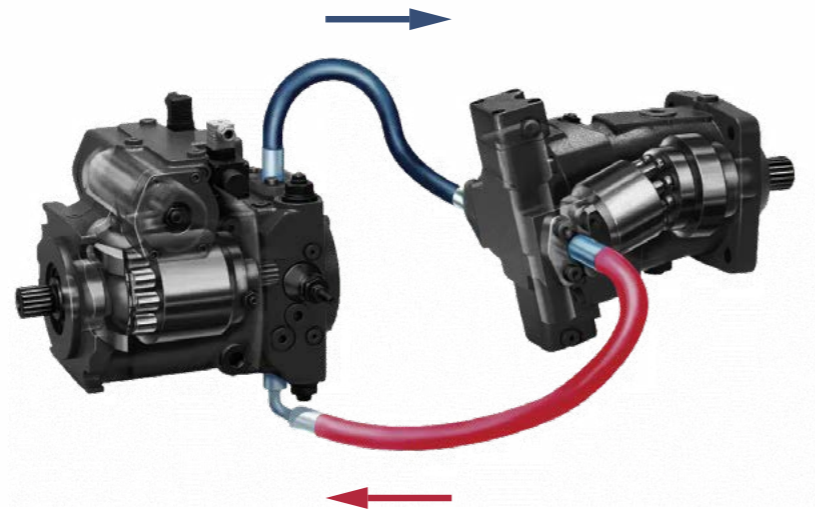

TRAVEL SPEED (km/h)

NOTE: Usable force will depend upon: machine weight, permitted traction, working duty cycle



- 1 Horn
- 2 High gear selector
- 3 Low gear selector
- 4 Variable gear speed increase / decrease
- 5 Windshield wipers / Pneumatic cleaning system activation

The traction force can be controlled precisely and safely with the **trackball on the joystick**

HEAVY DUTY UNDERCARRIAGE.

The FAE PT200 undercarriage is designed to provide maximum operating performance and reliability, even in the most demanding conditions.

Prime quality **Berco components**. Chains with lifetime lubrication offer longer life than conventional chains as well as greater operator comfort. Solid, reliable dozer-type rollers. **Oscillating undercarriage technology** for superior traction and comfort. Two options available for roller guards to better adapt to different working environments.

Conventional geometry ensures a **low center of gravity** and provides **optimal contact between chain and drive wheel**. Two fundamental elements for the best possible work, even on slopes. The FAE PT200 wheelbase also extends the area over which the load is distributed, which means **lower specific pressure against the ground**.

The frames of the PT200 undercarriage are designed to withstand major stresses and make maintenance easier.

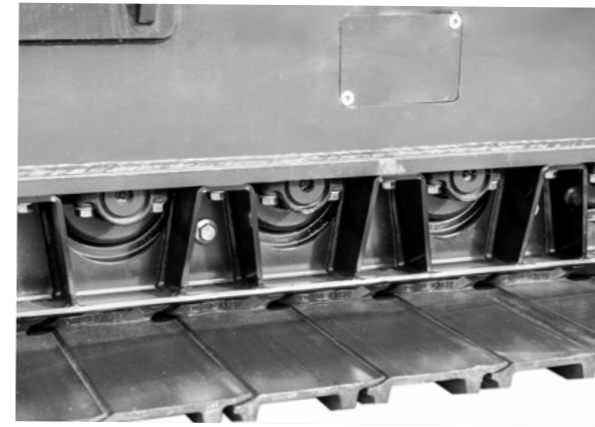

Solid rock guards

2 **slide** configurations to adapt to any terrain



Single grouser - 500 mm (Standard)

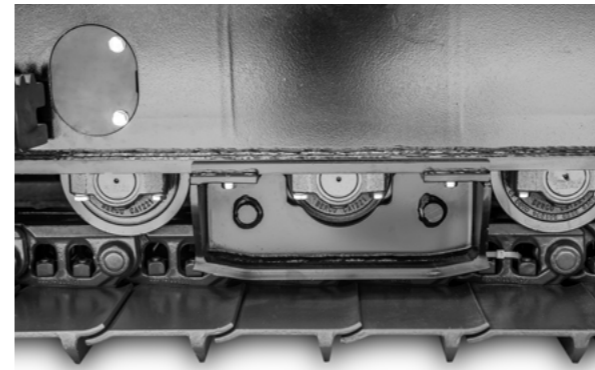

Chain guide



Single grouser - 700 mm (Option)



Oscillating **undercarriage technology** boosts grip and comfort

A SERIOUSLY COMFORTABLE CAB.

The cab of the FAE PT200 is designed for those who work in extreme conditions. It is ergonomic, soundproof and guarantees optimal visibility, making it an industry benchmark.

Joysticks built into the pneumatic suspension seat allow for easy, precise operation of the PT200. The controls on the side console are distributed to make them user friendly, and the 7" color display keeps the essential carrier parameters in view at all times.

ROPS/FOPS/OPS certification meets the highest standards of operator safety, even in the most demanding applications. The air conditioning system vents located throughout the cabin provide all the comfort the operator needs, in hot or cold weather. An optional cabin pressurization system is also available.

The large, **12-mm thick, impact and scratch-resistant Lexan™ windows** provide excellent visibility. Powerful LED work lights offer broad coverage, ensuring precise, safe work in all conditions.

Each and every item in the cabin has been carefully **designed with ergonomics in mind.**



7" electronic color **display**

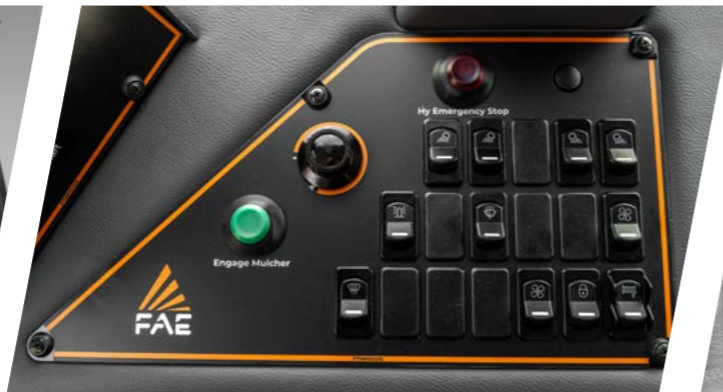

User-friendly side **console**



Powerful **air conditioning system**



Optional **rear view camera**



EASY TO USE, EASY TO MAINTAIN.

Everything about the FAE PT200 is designed to be effortless, from operation to maintenance.

Access to the engine compartment is easier with the **large doors with shock-resistant closures**. The compartment is also protected by micro-

perforated plates that prevent material from getting inside. Accessing the filters, tanks and hydraulic system components is easier with the large engine compartment and its organized interior layout. The large doors and **tilting cab** ensure easy maintenance, whether checking fluid levels or running

routine checks and more. In addition, a **heavy duty kit** can be installed to add an extra degree of air filtration and extend the life of the engine air filter.

The PT200's efficient cooling system comes standard with a **radiator with anti-clogging fins** specially

designed by FAE. It can also be integrated with reversible, proportional fans that ensure peak performance and maximize radiator core cleanliness. In fact, the fans are regulated by the machine's control unit, adjusting the tilt of the blades according to the operating temperature. This optimizes airflow and also saves fuel.



Level control is simplified by an organized layout (1)



The **large rear doors** have safety catches (2)



Fluid level indicators are clear and easy to locate (3)

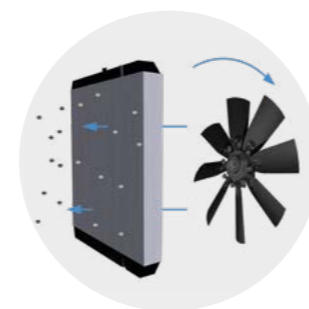

A **reversible fan** maximizes radiator efficiency (4)

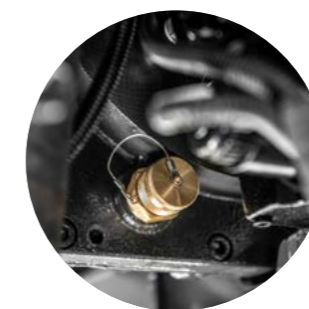

Couplings make it possible to quickly **drain fluids** without leaks (5)



FORESTRY MULCHERS FOR SPECIAL VEHICLES - PT

140/U/PT

Hydraulic mulcher with Sonic technology.

The 140/U/PT is the smallest model in the product line. Its small size makes it ideal for clearing corridors in the woods for seismic surveys and oil exploration. The sturdy frame means it can be used with tracked vehicles.



Sonic System



Ø 25 cm max



FORESTRY MULCHERS FOR SPECIAL VEHICLES - PT

BL4/PT

Forestry mulchers with Sonic technology.

High productivity and durability are key features of the BL4/PT forestry mulcher with Bite Limiter and Sonic technology, which can mulch vegetation up to 30 cm in diameter.



Sonic System



Ø 30 cm max



Guard frame hydraulic control or manual adjustment (optional)

Hydraulically controlled hood to adjust final product size

Ripper teeth for the push frame (optional)

Possibility to have optional rotors and teeth

Adjustable skids

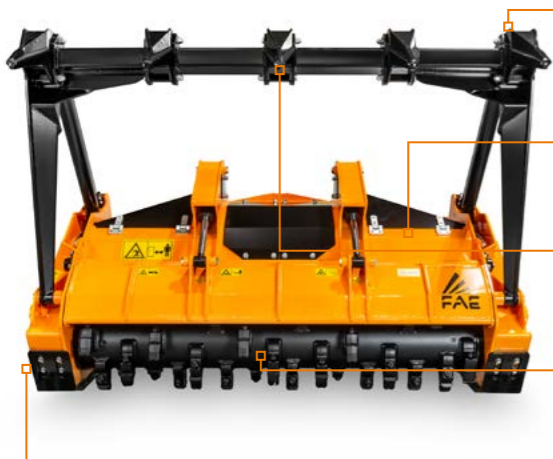

Hydraulic rear hood for an optimal material sizing and control

Ripper teeth for push frame (option)

Replaceable internal wear plate for high reliability and easy replacement

Possibility to have optional rotors and tooth

Adjustable skids

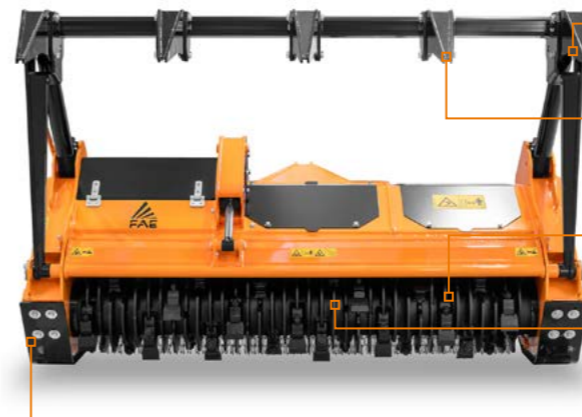

MODEL	140/U/SONIC/PT200-140	140/U/SONIC/PT200-175	140/U/SONIC/PT200-200
Head type	Mulcher	Mulcher	Mulcher
Working width (mm)	1407	1827	2067
Total width (mm)	1751	2171	2411
Weight (kg)	1550	1700	1800
Rotor diameter (mm)	450	450	450
Max shredding diameter (mm)	250	250	250
No. teeth type C/3+C/3/SS	28+4	38+4	42+2
type I + C/3/SS	40+2	54+2	60+2
No. blades type BL + C/3/SS	22+2	30+2	34+2

Data refers to machine as standard. The technical data in this catalogue may be altered without prior notice.

MODEL	BL4/SONIC/PT200-175	BL4/SONIC/PT200-200
Head type	Mulcher	Mulcher
Working width (mm)	1827	2067
Total width (mm)	2200	2440
Weight (kg)	1580	1710
Rotor diameter (mm)	465	465
Max shredding diameter (mm)	300	300
No. blades type BL/MAX	32	36

Data refers to machine as standard. The technical data in this catalogue may be altered without prior notice.

ROTOR TYPE C



TOOTH C/3 (standard) TOOTH C/3/HD (option) BLADE BL (option) TOOTH STCL/3 (standard) TOOTH K/3 (option)

ROTOR TYPE I



TOOTH I (option)

ROTOR BL



BLADE BL (standard) TOOTH C/3/SS (L/R) (side scraper)

ROTOR TYPE BL



BLADE BL/MAX (standard) TOOTH C/3/MAX (option)

STUMP CUTTERS FOR SPECIAL VEHICLES - PT

200/SC/PT

Hydraulic stump cutters.

The 200/SC/PT can shred large stumps and roots up to 50 cm depth. The hydraulic and proportional swing control allows to work on wide surfaces without moving the vehicle.



Ø 50 cm max



Depth 50 cm



BLADE FOR SPECIAL VEHICLES - PT

Dozer Blade PT

Eight-way dozer blade with heavy-duty structure and 2400 mm width. Designed for rough and finish grading in dirt and leveling, the FAE Dozer blade features interchangeable Hardox® wear-resistant cutting edges, a guarantee of resistance and reliability. Thanks to the hydraulic control of the movements, the blade can reach 15° of angle and 10° of side-tilt in both directions. The hydraulic system is equipped with relief valves to protect it from overload in the angle and side-tilt movements.



Hydraulic and proportional swing control

VT hydraulic motor and Block valves with double relief and anti-cavitation valves

Auxiliary and support blade for better grinding performance

Poly Chain belt transmission optimal power management

Interchangeable protection chains with safely deflects debris limit the escape of the shredded material

MOVEMENTS RANGE



1. Side-tilt



2. Lift

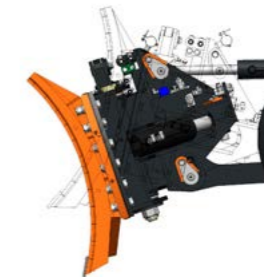

3. Front-tilt

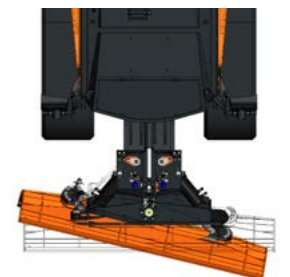

4. Angle

The 8-way movement allows side-tilting (1), lifting/lowering (2), front-tilting (3) and angle (4) the blade, all from the vehicle cabin.

TECHNICAL SPECIFICATIONS

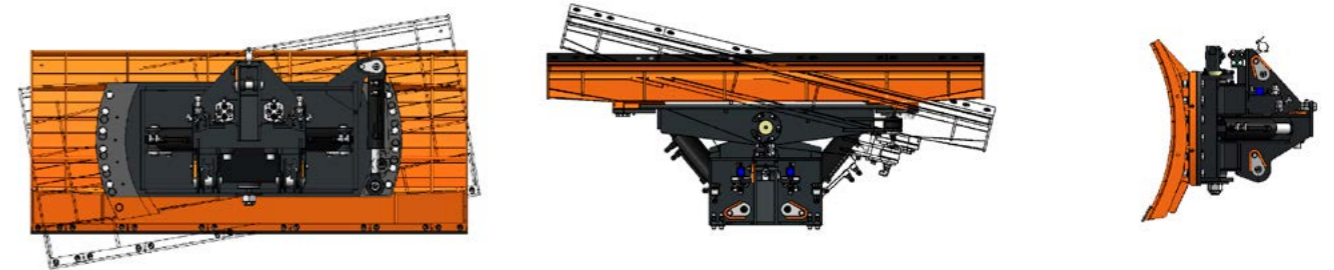

MODEL	200/SC/PT200
Head type	Stump cutter
Working width max range (mm)	1200
Blade width (mm)	1167
Weight (Kg)	1755
Disc rotor diameter (mm)	815
Disc rotor width (mm)	160
Max working depth (mm)	500
Max shredding diameter (mm)	500
No. teeth type M/1+M/2+M/3+M/4	12+3+12+3

Data refers to machine as standard. The technical data in this catalogue may be altered without prior notice.

ROTOR DISC



TOOTH M/3 (standard)



TOOTH M/1 (standard)



TOOTH M/4 (standard)



TOOTH M/2 (standard)

MODEL	Dozer Blade PT200-240
A. Blade width (mm)	2400
B. Width fully angled (mm)	2320
C. Moldboard height (mm)	970
D. Overall length with attachment plate (mm)	640
E. Blade angle	±15°
F. Center blade-left edge distance (when fully angled) (mm)	1055
G. Center blade-right edge distance (when fully angled) (mm)	1265
H. Blade side-tilt	±10°
Weight (kg)	1340
Moldboard thickness (mm)	15

Data refers to machine as standard. The technical data in this catalogue may be altered without prior notice.

PT200

TECHNICAL SPECIFICATIONS.



188 hp | Tier 4 Final / Stage V

STANDARD EQUIPMENT

DOC/DPF/SCR after-treatment system	Comfort driver's seat (heated and air suspended)
CAT C4.4 Acert turbocharged and after-cooled engine	Ergonomic joysticks
Hydrostatic transmission	Heating and air conditioning system
Hydrostatic transmission attachments	Double emergency exit and roof hatch handle to open from the outside
Load Control System	12-mm Lexan cabin windshields
H frame with tilting system	Cabin dust filtration
Oscillating undercarriage	7" LCD color display
500-mm single-grouser steel pads, lubricated chain, dozer-roller version	Multimedia - Bluetooth radio
Combined aluminum cooler with anti-clogging fins	Additional LED headlights
ROPS/FOPS/OPS-approved cabin	Sonic System
Hydraulic winch control kit and push frame	

DIMENSIONS

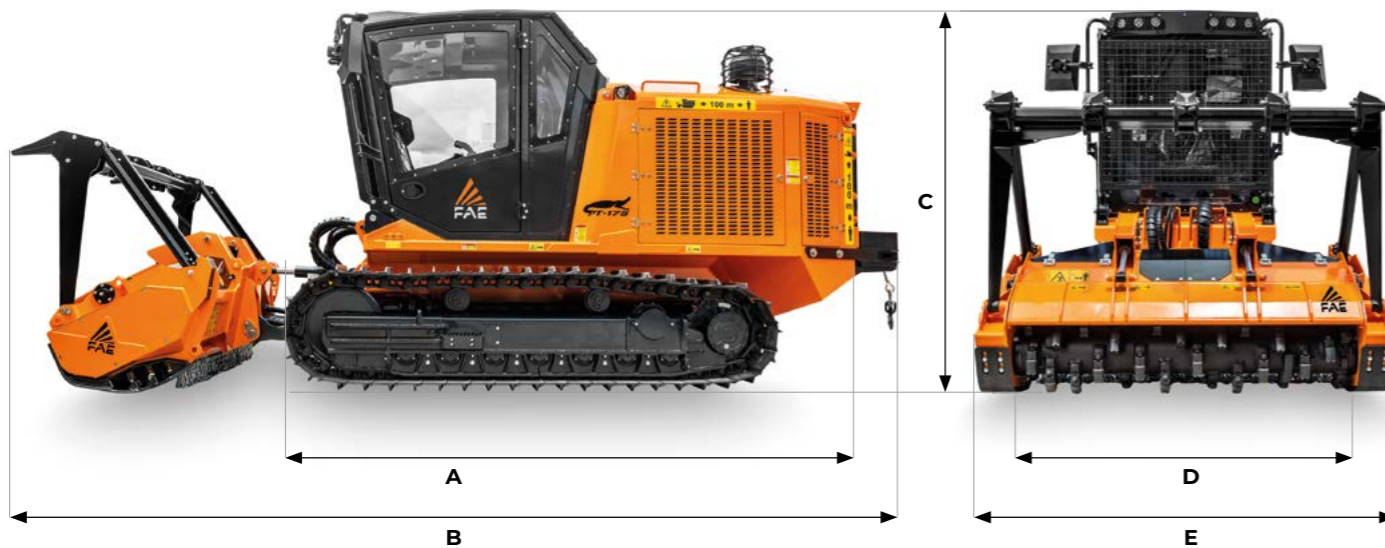

A Overall length without attachment	4518 mm	C Max height	2654 mm
B Transport length with 140/U/PT attachment on ground and winch	6422 mm	D Overall track width	2050 mm (with 500 mm pads)
		E See attachments table	

PT200 Tier 4 Final / Stage V

Engine Gross Power	188 hp
Engine Emission	U.S. EPA Tier 4 Final / EU Stage V
Travel Pumps	2 - EP control - 60 cc - Danfoss
Travel Motors	2 - HY control - 60 cc - Rexroth
Max Travel Pressure	420 Bar
Attachment Pump	1 - EP control - 100 cc - Danfoss
Max Mulcher Pressure	350 Bar
Hydraulic Oil Tank Capacity	230 L
Fuel Tank Capacity	250 L
DEF AdBlue® Tank	19 L
Track Chain	155 mm pitch - Lubricated - Berco (std equipment with 500 mm pads)
Lower Rollers	7 + 7 Single Flange
Carrier Rollers	2 + 2
Voltage	24 volt
Max Forward Speed	7 Km/h
Max Reverse Speed	7 Km/h
Gradeability	45° vertical, 32° lateral
Operating Weight	8600 Kg (std equipment with 500 mm pads) 8915 Kg (std equipment with 700 mm pads)
Ground Pressure	0,28 Kg/cm ² (std equipment / 700 mm pads / 140/U/SONIC/PT200-175)

ATTACHMENT

MODEL	140/U/SONIC/ PT200-140	140/U/SONIC/ PT200-175	140/U/SONIC/ PT200-200	BL4/SONIC/ PT200-175	BL4/SONIC/ PT200-200	200/SC/ PT200
Head type	Mulcher	Mulcher	Mulcher	Mulcher	Mulcher	Stump cutter
Working width (mm)	1407	1827	2067	1827	2067	-
Working width max range (mm)	-	-	-	-	-	1200
Total width (mm)	1751	2171	2411	2200	2440	1167
Weight (Kg)	1550	1700	1800	1580	1710	1755
Rotor diameter (mm)	450	450	450	465	465	-
Disc rotor diameter (mm)	-	-	-	-	-	815
Disc rotor width (mm)	-	-	-	-	-	160
Max working depth (mm)	-	-	-	-	-	500
Max shredding diameter (mm)	250	250	250	300	300	500
No. teeth type C/3+C/3/SS	28+4	38+4	42+2	-	-	-
type I + C/3/SS	40+2	54+2	60+2	-	-	-
No. teeth type M/1+M/2+M/3+M/4	-	-	-	-	-	12+3+12+3
No. blades type BL + C/3/SS	22+2	30+2	34+2	-	-	-
No. blades type BL/MAX	-	-	-	32	36	-

TEETH

140/U/PT			BL4/PT	200/SC/PT
ROTOR C	ROTOR I	ROTOR BL	ROTOR BL	DISC ROTOR
C/3 (standard)	I (option)	BLADE BL (option)	BLADE BL/MAX (standard)	M/1 (standard)
C/3/HD (option)			C/3/MAX (option)	M/2 (standard)
K/3 (option)				M/3 (standard)
BLADE BL (option)				M/4 (standard)
STCL/3 (option)				
C/3/SS (left/right) (side scraper)	C/3/SS (left/right) (side scraper)	C/3/SS (left/right) (side scraper)		

OPTIONS

OPTIONS

Rear winch with 6-tpulling force	Chain guide
Canopy	Roller and drive wheel stone guard
Cabin pressurization system	Reversible and proportional radiator fan
Front cabin grille	Bio-oil
Visibility Package (LED headlights + back-up camera)	Heavy-duty filtration system (drainage and ejector kit)
6-mm Lexan cabin windshields	Engine and hydraulic oil pre-heating system
Air shutoff valve	Custom color
Easy Service package (oil filling pump and service lights)	Forestry protection kit (cabin side window grilles + engine compartment door protectors)
700-mm single-rib steel slides	Active Power Management

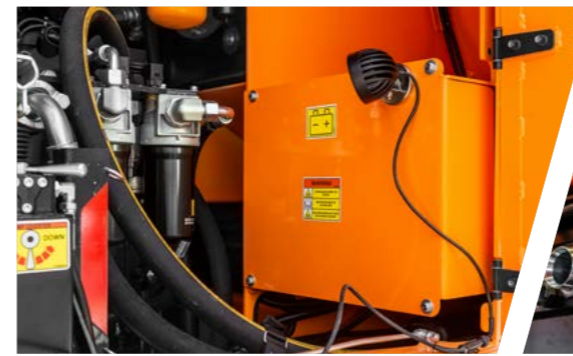

Easy Service package (service light)



Easy Service package (oil filling pump)

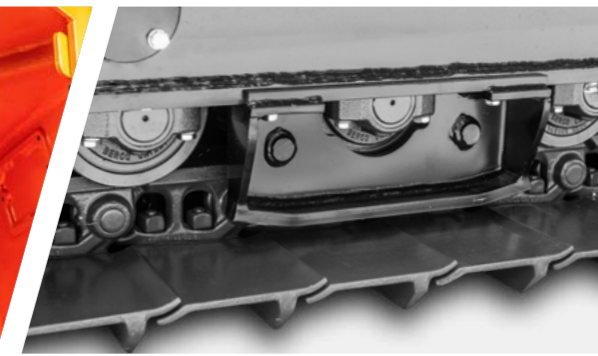

Chain guide

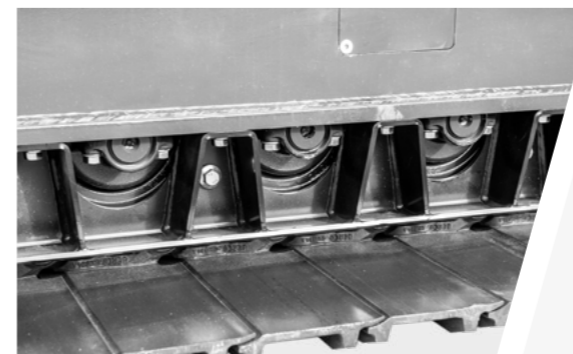

Roller and drive wheel stone guard

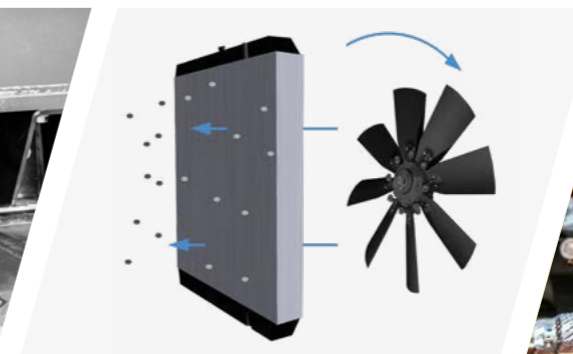

Reversible and proportional radiator fan



Heavy-duty filtration system (ejector)



Rear winch with 6-tpulling force



Canopy



Cabin pressurization system



Heavy-duty filtration system (drainage)



Engine and hydraulic oil pre-heating system



Air shutoff valve



Front cabin grille



Visibility Package (back-up camera)



Visibility-Paket (LED-Scheinwerfe)



Forestry protection kit (cabin side window grilles + engine compartment door protectors)



700-mm single-rib steel slides

FAE PT300

THE TRACKED CARRIER THAT IS READY FOR ANYTHING.

The FAE PT300 is the ideal tracked carrier for the most difficult tasks, whether managing woods and forests or creating firebreaks near electrical lines, oil and gas pipelines. Its solid structure with oscillating undercarriage make it compatible with a wide variety of FAE hydraulic units: forestry mulchers, cutters, stone crushers, stump cutters and dozer blades. The high-power CAT C7.1 Acert inline six-cylinder engine with low operating weight makes it possible to work on steep slopes and soft ground. The hydraulic system guarantees reliability and efficiency. The spacious cab is unrivaled when it comes to comfort, ergonomics and operator safety.

POWERFUL

The flexibility and reliability of one of the world's most widely used inline six-cylinder engines. The Caterpillar C7.1 Tier 4 Final/Stage V engine delivers 302 hp, while the Tier 3/Stage III A version provides 275 hp. Always top-notch performance supported by a global service network.

NIMBLE

The FAE PT300 takes working on steep, soft, uneven and swampy terrains in stride. Vertical slopes of 45° and lateral slopes of 35°. High power, low operating weight. Minimum pressure against the ground: 0.29 kg/cm².

TECHNOLOGICAL

High-tech body and soul. An integrated system developed by FAE to ensure maximum performance. With a network of sensors to monitor key operating parameters, everything in the PT300 can be easily fine-tuned.

COMFORTABLE

Designed with total operator comfort in mind. ROPS/FOPS/OPS cabs - the industry benchmark. High Lexan™ windows. Ergonomic joysticks. Pneumatic seat. 7" color display to monitor and modify all operating functions.



VERSATILE

Born flexible. The construction features of the FAE PT300 enable it to accommodate forestry mulcher (also with exclusive Sonic technology), stump cutters and dozer blades. Always the ideal configuration to manage woods and forests as well as create firebreaks near electrical lines, oil and gas pipelines.

AN ENGINE THAT'S ALWAYS READY TO GO

You can count on the FAE PT300 engine. The **Caterpillar C7.1 Acert** inline six-cylinder engine is one of the world's most popular and highly respected engines. Equipped with twin turbochargers with after cooler and Acert technology, the Tier 4 Final/ Stage V version of this engine delivers an impressive 302 hp. Efficient, reliable, with superb consumption/ power ratio.

Compliance with the **Tier 4 Final / Stage V** standard is guaranteed with the combination of diesel particulate filter (DPF), selective catalytic reduction (SCR) and diesel oxidation catalyst (DOC) technologies.

A combination that maximizes uptime and requires minimal maintenance over time, achieved by passive regeneration that does not require interrupting the work.

The FAE PT300 is also available in a **Tier 3 / Stage III A** version for emission-free markets, rated at 275 hp.

The generous 7-liter displacement and a cooling system designed specifically for the FAE PT300 ensure that both configurations can offer peak performance in both heavy-duty applications and when working in tropical climates.



Engine
Tier 4 Final / Stage V

The simple, uncluttered **internal layout** is synonymous of reliability



Optimized airflow for working in extreme conditions

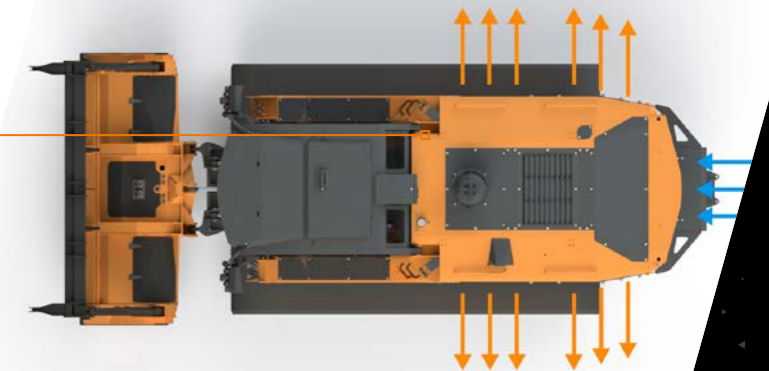

Easy access to **filters** makes maintenance quick and easy

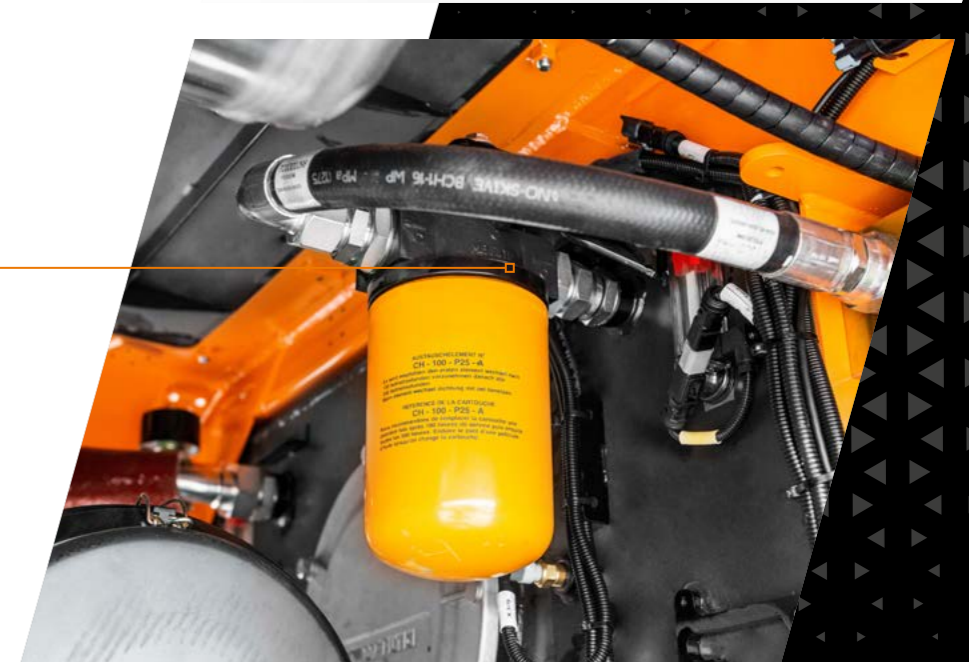

EFFICIENT, RELIABLE TRANSMISSION.

The transmissions designed for the FAE PT300 are based on two fundamental concepts: technology and integration. **Electronically-controlled pumps and sensors and a dedicated control unit**, working together to deliver maximum performance. The systems are designed to enable the CAT C7.1 Acert engine to operate at optimal rpms at all times.

The FAE PT300's **hydrostatic transmission** also serves to dampen operating loads. This ensures that the carrier and its key components are subjected to less stress, reducing wear and tear. The end result is greater durability than a mechanical transmission.

An added benefit of the FAE PT300's hydrostatic transmission is that they can accommodate a **wide variety of dedicated FAE equipment** such as forestry mulchers, stump cutters, stump grinders and dozer blades.

The PT300 can be equipped with **Active Power Management**, an intelligent FAE system that automatically manages vehicle advancement in relation to the force absorbed by the rotor. This feature also helps the machine automatically adapt to the contour of the terrain. The operator can now concentrate on the job at hand, for higher productivity.

Diagram of the FAE PT300 **hydrostatic transmission**: simple and effective

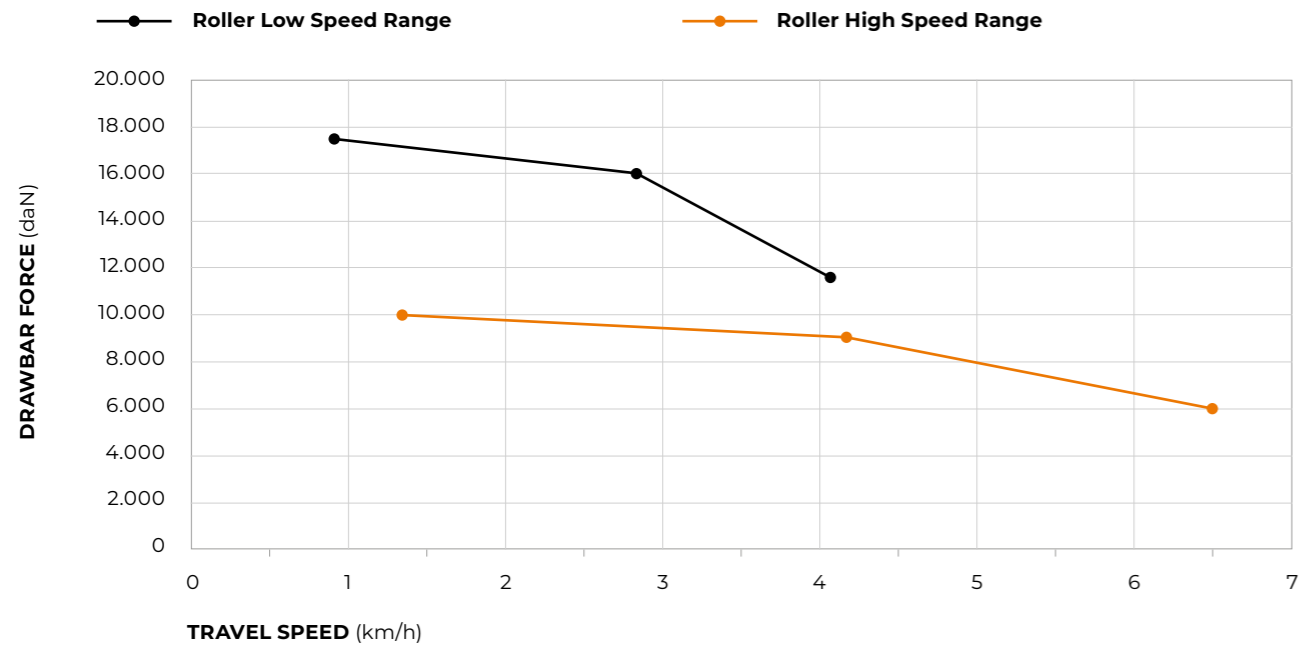
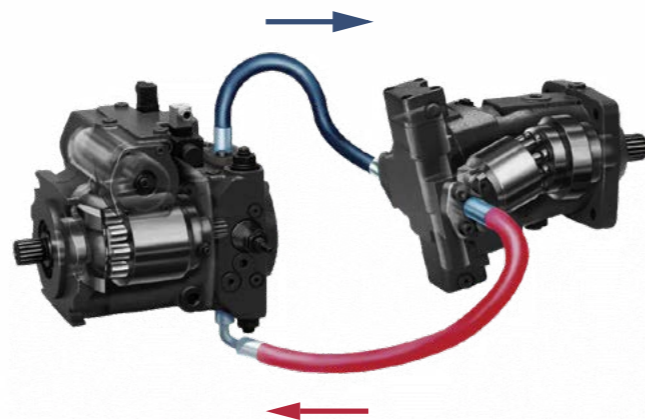

TRAVEL SPEED (km/h)

NOTE: Usable force will depend upon: machine weight, permitted traction, working duty cycle



- 1 Horn
- 2 High gear selector
- 3 Low gear selector
- 4 Variable gear speed increase / decrease
- 5 Windshield wipers / Pneumatic cleaning system activation

The traction force can be controlled precisely and safely with the **trackball on the joystick**

HEAVY DUTY UNDERCARRIAGE.

The FAE PT300 undercarriage is designed to provide maximum operating performance and reliability, even in the most demanding conditions.

Prime quality **Berco components**. Chains with lifetime lubrication offer longer life than conventional chains as well as greater operator comfort. Solid, reliable dozer-type rollers. Oscillating undercarriage technology for superior traction and comfort. Two options available for roller guards to better adapt to different working environments.

Conventional geometry ensures a **low center of gravity** and provides **optimal contact between chain and drive wheel**. Two fundamental elements for the best possible work, even on slopes. The FAE PT300 wheelbase also extends the area over which the load is distributed, which means **lower specific pressure against the ground**.

The frames of the PT300 undercarriage are designed to withstand major stresses and make maintenance easier.

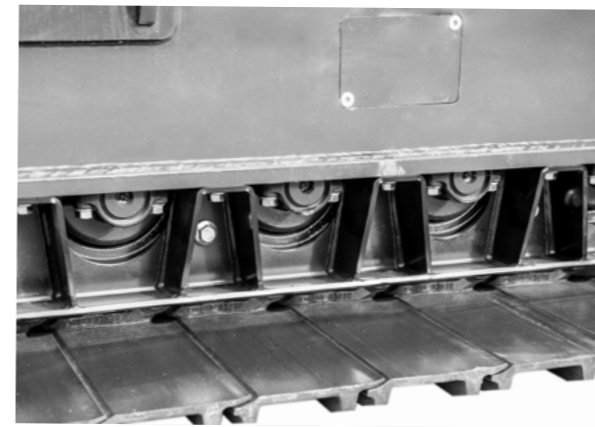

Solid rock guards

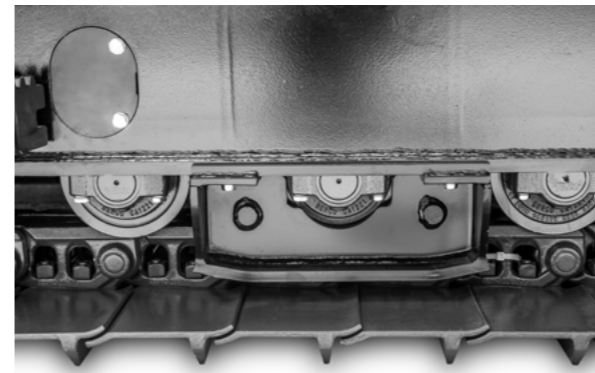

Chain guide

3 **slide** configurations to adapt to any terrain



Double grouser - 800 mm (Option)



Single grouser - 660 mm (Standard)



Single grouser - 800 mm (Option)



Oscillating **undercarriage technology** boosts grip and comfort

A SERIOUSLY COMFORTABLE CAB.

The cab of the FAE PT300 is designed for those who work in extreme conditions. It is ergonomic, soundproof and guarantees optimal visibility, making it an industry benchmark.

Joysticks built into the pneumatic suspension seat allow for easy, precise operation of the PT300. The controls on the side console are distributed to make them user friendly, and the 7" color display keeps the essential carrier parameters in view at all times.

ROPS/FOPS/OPS certification meets the highest standards of operator safety, even in the most demanding applications. The air conditioning system vents located throughout the cabin provide all the comfort the operator needs, in hot or cold weather. An optional **cabin pressurization system** is also available.

The large, **12-mm thick, impact and scratch-resistant Lexan™ windows** provide excellent visibility. Powerful LED work lights offer broad coverage, ensuring precise, safe work in all conditions.

Each and every item in the cabin has been carefully **designed with ergonomics in mind.**



7" electronic color **display**

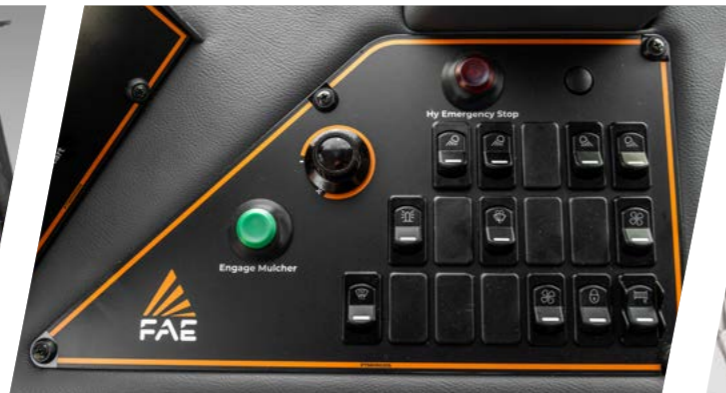

User-friendly side **console**



Powerful **air conditioning system**



Optional **rear view camera**



EASY TO USE, EASY TO MAINTAIN.

Everything about the FAE PT300 is designed to be effortless, from operation to maintenance.

Access to the engine compartment is easier with the **large doors with shock-resistant closures**. The compartment is also protected by micro-perforated plates that prevent material from getting

inside. Accessing the filters, tanks and hydraulic system components is easier with the large engine compartment and its organized interior layout. The large doors and **tilting cab** ensure easy maintenance, whether checking fluid levels or running routine checks and more. A **powerful air compressor comes standard for daily cleaning**. In addition, a **heavy**

duty kit can be installed to add an extra degree of air filtration and extend the life of the engine air filter.

The PT300's efficient cooling system comes standard with a **radiator combined with anti-clogging fins** specially designed by FAE. It can also be integrated with reversible, proportional fans that ensure peak

performance and maximize radiator core cleanliness. In fact, the fans are regulated by the machine's control unit, adjusting the tilt of the blades according to the operating temperature. This optimizes airflow and also saves fuel.



Level control is simplified by an organized layout (1)



The **large rear doors** have safety catches (2)



Fluid level indicators are clear and easy to locate (3)

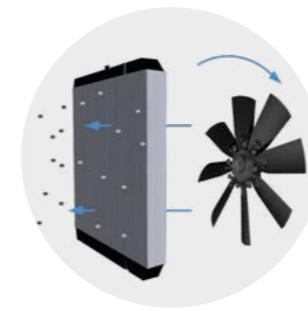

A **reversible fan** maximizes radiator efficiency (4)

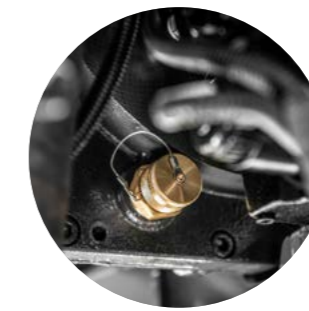

Couplings make it possible to quickly **drain fluids** without leaks (5)



The **air compressor** makes daily cleaning easier



FORESTRY MULCHERS FOR SPECIAL VEHICLES - PT

200/U/PT

Heavy duty hydraulic mulcher with Sonic technology.

The 200/U/PT combines compact maneuverability with the performance of larger machines. It is strong and highly productive for mulching bushes, branches and trees up to 35 cm in diameter.



Sonic System



Ø 35 cm max



FORESTRY MULCHERS FOR SPECIAL VEHICLES - PT

300/U/PT

Heavy duty hydraulic mulcher with Sonic technology.

The 300/U/PT mulcher is highly productive, strong, and lightweight, with a fixed-teeth rotor that lets it mulch plants and trunks up to 40 cm in diameter.



Sonic System



Ø 40 cm max

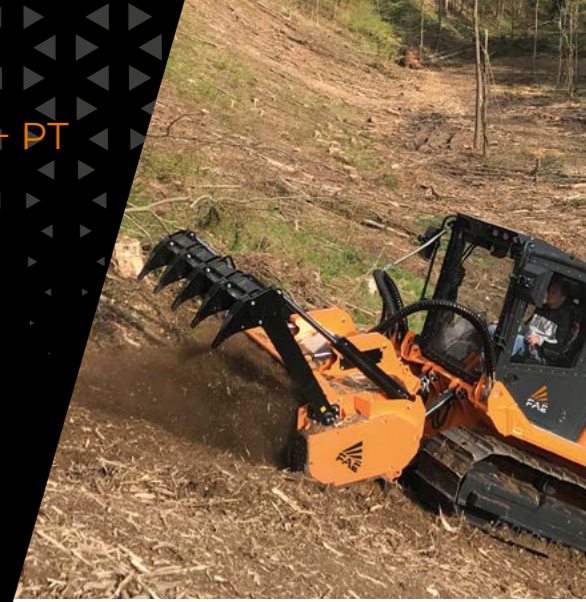

MODEL	200/U/SONIC/PT300/PT400-200	200/U/SONIC/PT300/PT400-210	200/U/SONIC/PT300/PT400-225
Head type	Trincia	Trincia	Trincia
Working width (mm)	2064	2148	2304
Total width (mm)	2464	2548	2704
Weight (kg)	2440	2510	2600
Rotor diameter (mm)	500	500	500
Max shredding diameter (mm)	350	350	350
No. teeth type C/3+C/3/SS	42+2	44+2	46+2

Data refers to machine as standard. The technical data in this catalogue may be altered without prior notice.

MODEL	300/U/SONIC/PT300/PT400-200
Head type	Mulcher
Working width (mm)	2064
Total width (mm)	2544
Weight with C-type (kg)	3500
Weight with B-type (kg)	3780
Rotor diameter (mm)	590
Max shredding diameter (mm)	400
No. teeth type B/3 + C/3/SS	72+2
type C/3+C/3/SS	44+2

Data refers to machine as standard. The technical data in this catalogue may be altered without prior notice.

ROTOR TYPE C



ROTOR TYPE BL



ROTOR TYPE I

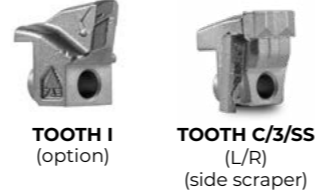

ROTOR TYPE B



ROTOR TYPE C

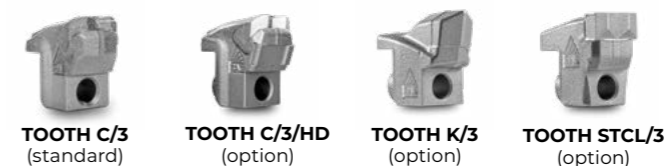

STUMP CUTTERS FOR SPECIAL VEHICLES - PT

300/SC/PT

Hydraulic stump cutters.

The 300/SC/PT can shred large stumps and roots up to 50 cm in diameter and 100 cm deep. The hydraulic and proportional swing control allows to work on wide surfaces without moving the vehicle.



Ø 50 cm max



Depth 100 cm



FORESTRY TILLERS FOR SPECIAL VEHICLES - PT

200/S/PT

Hydraulic forestry tiller.

The 200/S/PT is lightweight and comes in different widths, making it perfect for different situation. The gear drive lets the rotor work at a slower speed than conventional belt-driven forestry mulchers.



Ø 30 cm max



Depth 30 cm



Hydraulic and proportional swing control

Hydraulic motor with relief valve

Poly Chain belt transmission
optimal power management

Interchangeable protection chains with safely deflects debris
limit the escape of the shredded material

Auxiliary and support blade
for better grinding performance



Dual transmission with side gearbox

180 cc hydraulic motor

Hydraulically controlled hood
to adjust final product size

MODEL	300/SC/PT300/PT400-220
Head type	Stump cutter
Working width max range (mm)	1450
Blade width (mm)	1050
Weight (kg)	2100
Disc rotor diameter (mm)	1020
Disc rotor width (mm)	160
Max working depth (mm)	1000
Max shredding diameter (mm)	500
No. teeth type M/1+M/2+M/3+M/4	24+4+24+4

Data refers to machine as standard. The technical data in this catalogue may be altered without prior notice.

MODEL	200/S/PT300/PT400-200	200/S/PT300/PT400-225	200/S/PT300/PT400-250
Head type	Fresa	Fresa	Fresa
Working width (mm)	2080	2320	2560
Total width (mm)	2352	2662	2902
Weight (kg)	2950	3162	3400
Rotor diameter (mm)	600	600	300
Max working depth (mm)	300	300	300
Max shredding diameter (mm)	300	300	600
No. teeth type B/3+C/3/SS	74+4	82+4	82+4

Data refers to machine as standard. The technical data in this catalogue may be altered without prior notice.

ROTOR DISC



TOOTH M/3
(standard)



TOOTH M/1
(standard)



TOOTH M/4
(standard)



TOOTH M/2
(standard)

ROTOR TYPE B



TOOTH B/3
(standard)



TOOTH B/3/HD
(option)



TOOTH G/3
(option)



TOOTH G/3/HD
(option)



TOOTH C/3/SS
(side scraper)

MULTITASKS FOR SPECIAL VEHICLES - PT

SFM/PT

Mulcher, stone crusher and cutter for the PT300.

The SFM/PT is a multitask attachment for the FAE PT300 tracked carrier, which can shred wood, crush stones and cut stumps or roots, all in one head.



Ø 20 cm max (Stones)
Ø 35 cm max (Trees)
Ø 45 cm max (Stump)



Depth 30 cm



BLADE FOR SPECIAL VEHICLES - PT

Dozer Blade PT

Eight-way dozer blade with heavy-duty structure and 2400 mm width. Designed for rough and finish grading in dirt and leveling, the FAE Dozer blade features interchangeable Hardox® wear-resistant cutting edges, a guarantee of resistance and reliability. Thanks to the hydraulic control of the movements, the blade can reach 15° of angle and 10° of side-tilt in both directions. The hydraulic system is equipped with relief valves to protect it from overload in the angle and side-tilt movements.



Interchangeable wear-resistant Hardox® plates

Hydraulically hood to adjust final product size

Transmission with side gearbox which maximizes power to the rotor

Adjustable Hardox® counter blade

MOVEMENTS RANGE

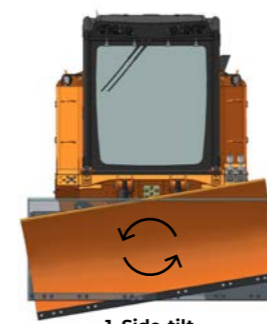

1. Side-tilt

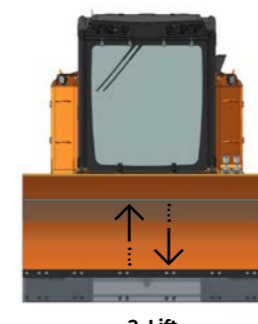

2. Lift



3. Front-tilt



4. Angle

The 8-way movement allows side-tilting (1), lifting/lowering (2), front-tilting (3) and angle (4) the blade, all from the vehicle cabin or from the remote control.

TECHNICAL SPECIFICATIONS

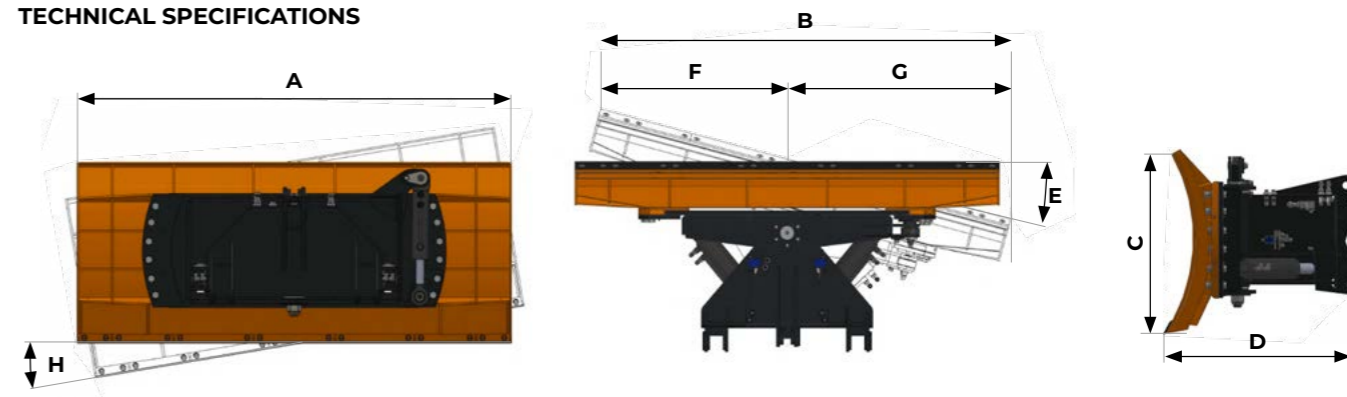

MODEL	SFM/PT300/PT400-225	
Head type	Multitask	
Working width (mm)	2310	
Total width (mm)	2620	
Weight (kg)	4215	
Max working depth (mm)	300	
Max shredding diameter (mm)	Stones	200
	Trees	350
	Stumps	450
Rotor diameter (mm)	670	
No. teeth type F/3 + STC/3/FP+BAZ	58+6+4	

Data refers to machine as standard. The technical data in this catalogue may be altered without prior notice.

ROTOR TYPE F



TOOTH F/3 (standard)



TOOTH STC/3/FP (side scraper)



TOOTH BAZ (side scraper)

MODEL	Lama Dozer PT300/PT400-240
A. Blade width (mm)	2400
B. Width fully angled (mm)	2320
C. Moldboard height (mm)	970
D. Overall length with attachment plate (mm)	1020
E. Blade angle	±15°
F. Center blade-left edge distance (when fully angled) (mm)	1055
G. Center blade-right edge distance (when fully angled) (mm)	1265
H. Blade side-tilt	±10°
Weight (kg)	1400
Moldboard thickness (mm)	15

Data refers to machine as standard. The technical data in this catalogue may be altered without prior notice.

PT300

TECHNICAL SPECIFICATIONS.



275 hp | CAT ENGINE | Tier 3 Stage III A

302 hp | CAT ENGINE | Tier 4 Final / Stage V

STANDARD EQUIPMENT

CAT C7.1 Acert turbocharged and after-cooled engine	Ergonomic joysticks
DOC/DPF/SCR after-treatment system	Heating and air conditioning system
Hydrostatic transmission	Double emergency exit and roof hatch handle to open from the outside
Hydrostatic transmission attachments	12-mm Lexan cabin windshields
H frame with tilting system	Cabin dust filtration
Oscillating undercarriage	7" LCD color display
660-mm single-grouser steel pads, lubricated chain, dozer-roller version	Multimedia - Bluetooth radio
Combined aluminum cooler with anti-clogging fins	LED working lights
ROPS/FOPS/OPS-approved cabin	Air compressor system
Comfort driver's seat (heated and air suspended)	Sonic System
Hydraulic winch control kit and push frame	Overhead to fixed lift conversion kit

DIMENSIONS

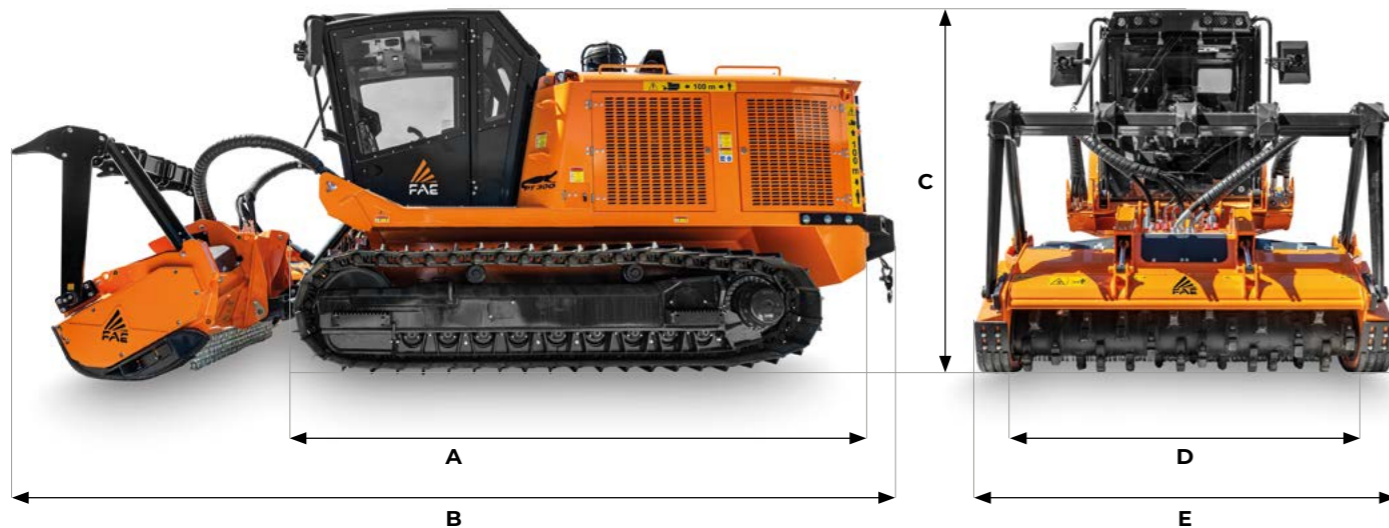

- A** Overall length without attachment 4950 mm
- B** Transport length with 200/U/PT attachment on ground and winch 6900 mm
- C** Max height 2785 mm
- D** Overall track width 2360 mm (with 660 mm pads)
- E** See attachments table

PT300 Tier 3 / Stage III A

PT300 Tier 4 Final / Stage V

Engine Gross Power	275 hp	302 hp
Engine Emission	U.S. EPA Tier 3 / EU Stage III A	U.S. EPA Tier 4 Final / EU Stage V
Travel Pumps	2 - EP control - 78 cc - Danfoss	2 - EP control - 78 cc - Danfoss
Travel Motors	2 - HY control - 80 cc - Danfoss	2 - HY control - 80 cc - Danfoss
Max Travel Pressure	420 Bar	420 Bar
Attachment Pump	1 - EP control - 130 cc - Danfoss	1 - EP control - 147 cc - Danfoss
Max Mulcher Pressure	350 Bar	350 Bar
Hydraulic Oil Tank Capacity	320 L	320 L
Fuel Tank Capacity	340 L	340 L
DEF AdBlue® Tank	-	16 L
Track Chain	171 mm pitch - lubricated - Berco (std equipment with 660 mm pads)	171 mm pitch - lubricated - Berco (std equipment with 660 mm pads)
Lower Rollers	6 + 6 Single Flange + 3 + 3 Double Flange	6 + 6 Single Flange + 3 + 3 Double Flange
Carrier Rollers	2 + 2	2 + 2
Voltage	24 volt	24 volt
Max Forward Speed	6,5 Km/h	6,5 Km/h
Max Reverse Speed	6,5 Km/h	6,5 Km/h
Gradeability	45° vertical, 35° lateral	45° vertical, 35° lateral
Operating Weight	11410 Kg (std equipment with 660 mm pads) 12010 Kg (std equipment with 800 mm pads DG)	11660 Kg (std equipment with 660 mm pads) 12060 Kg (std equipment with 800 mm pads DG)
Ground Pressure	0,29 Kg/cm² (std equipment / 800 mm pads DG / 200/U/SONIC/PT300/PT400-225)	0,29 Kg/cm² (std equipment / 800 mm pads DG / 200/U/SONIC/PT300/PT400-225)

ATTACHMENT

MODEL	200/U/SONIC/PT300/PT400-200	200/U/SONIC/PT300/PT400-210	200/U/SONIC/PT300/PT400-225	300/U/SONIC/PT300/PT400-200
Head type	Mulcher	Mulcher	Mulcher	Mulcher
Working width (mm)	2064	2150	2304	2064
Total width (mm)	2464	2548	2704	2544
Weight (kg)	2440	2510	2600	3500 (C) - 3780 (B)
Rotor diameter (mm)	500	500	500	590
Max shredding diameter (mm)	350	350	350	400
No. teeth type B/3 + C/3/SS	-	-	-	72+2
type C/3+C/3/SS	42+2	44+2	46+2	44+2

MODEL	200/S/PT300/PT400-200	200/S/PT300/PT400-225	200/S/PT300/PT400-250	300/SC/PT300/PT400-200	SFM/PT300/PT400-225
Head type	Tiller	Tiller	Tiller	Stump cutter	Multitask
Working width (mm)	2080	2320	2560	-	2310
Working width max range (mm)	-	-	-	1450	-
Total width (mm)	2352	2662	2902	1050	2620
Blade width (mm)	-	-	-	1050	-
Weight (kg)	2950	3162	3400	2100	4215
Rotor diameter (mm)	600	600	600	1020 (Disc rotor)	670
Disc rotor width (mm)	-	-	-	160	-
Max working depth (mm)	300	300	300	1000	300
Max shredding diameter (mm)	300	300	300	500	200 (stones) - 350 (trees) - 450 (stumps)
No. teeth type B/3+C/3/SS	74+4	82+4	96+4	-	-
type M/1+M/2+M/3+M/4	-	-	-	24+4+24+4	-
type F/3+STC/3/FP+BAZ	-	-	-	-	58+6+4

TEETH

200/U/PT	300/U/PT	200/S/PT	300/SC/PT	SFM/PT
ROTOR C	ROTOR C	ROTOR B	ROTOR B	DISC ROTOR
C/3 (standard)	C/3 (standard)	B/3 (standard)	B/3 (standard)	M/1 (standard)
C/3/HD (option)	C/3/HD (option)	B/3/HD (option)	B/3/HD (option)	M/2 (standard)
K/3 (option)	K/3 (option)		G/3 (option)	M/3 (standard)
STCL/3 (option)	STCL/3 (option)		G/3/HD (option)	M/4 (standard)
C/3/SS (side scraper)	C/3/SS (side scraper)	C/3/SS (side scraper)	C/3/SS (side scraper)	
				ROTOR F
				F/3 (standard)
				STC/3/FP (side scraper)
				BAZ (side scraper)

OPTIONS

OPTIONS	
Rear winch with 6-t traction force	Chain guide
Canopy	6-mm Lexan cabin windshields
Bio-oil	Reversible and proportional radiator fan
Cabin pressurization system	Heavy-duty filtration system (drainage and ejector kit)
Front cabin grille	Custom color
Air window cleaning system	Engine and hydraulic oil pre-heating system
Visibility Package (LED headlights + back-up camera)	Air shutoff valve
Easy Service package (oil filling pump and service lights)	Automatic fire-extinguishing system
800-mm single-grouser steel pads	Forestry protection kit (cabin side window grilles + engine compartment door protectors)
800-mm double-grouser steel pads	Active Power Management system (Load Control and Floating System)
Roller and drive wheel undercarriage stone guard	



Visibility Package (back-up camera)



Visibility-Paket (LED-Scheinwerfer)



Easy Service package (service light)



Easy Service package (oil filling pump)

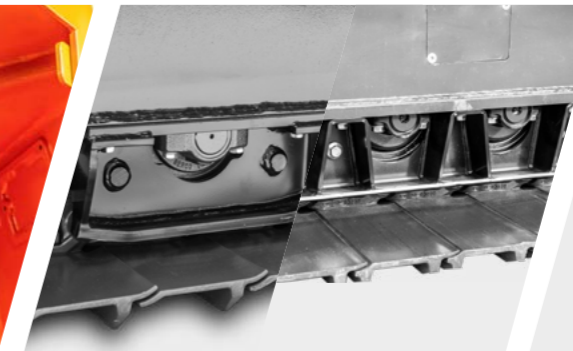

Chain guides - Rock guards



Forestry protection kit (cabin side window grilles + engine compartment door protectors)



Rear winch with 6-t traction force



Canopy



H frame with tilting system

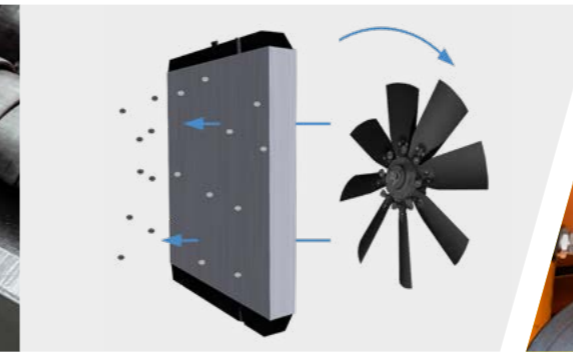

Reversible and proportional radiator fan



Heavy-duty filtration system (ejector)



Heavy-duty filtration system (drainage)



Cabin pressurization system



Front cabin grille



Air window cleaning system



Engine and hydraulic oil pre-heating system



Air shut-off system



Automatic fire-extinguishing system

FAE PT400

THE POWERFUL AND VERSATILE TRACKED VEHICLE.

The FAE PT400 is the ideal tracked carrier for the most difficult tasks, whether managing woods and forests or creating firebreaks near electrical lines, oil and gas pipelines. Its solid structure with oscillating undercarriage make it compatible with a wide variety of FAE hydraulic units: forestry mulchers, cutters, stone crushers, stump cutters and dozer blades. The high-power Cummins L9 inline six-cylinder engine with low operating weight makes it possible to work on steep slopes and soft ground. The hydraulic system guarantees reliability and efficiency. The spacious cab is unrivaled when it comes to comfort, ergonomics and operator safety.

POWERFUL

The flexibility and reliability of one of the world's most widely used inline six-cylinder engines. The Cummins L9 Tier 4 Final/ Stage V engine delivers 380 hp. Always top-notch performance supported by a global service network.

NIMBLE

The FAE PT400 takes working on steep, soft, uneven and swampy terrains in stride. Vertical slopes of 45° and lateral slopes of 35°. High power, low operating weight. Minimum pressure against the ground: 0,32 kg/cm².

TECHNOLOGICAL

High-tech body and soul. An integrated system developed by FAE to ensure maximum performance. With a network of sensors to monitor key operating parameters, everything in the PT400 can be easily fine-tuned.

COMFORTABLE

Designed with total operator comfort in mind. ROPS/FOPS/OPS cabs - the industry benchmark. High Lexan™ windows. Ergonomic joysticks. Pneumatic seat. 7" color display to monitor and modify all operating functions.



VERSATILE

Born flexible. The construction features of the FAE PT400 enable it to accommodate forestry mulcher (also with exclusive Sonic technology), stump cutters and dozer blades. Always the ideal configuration to manage woods and forests as well as create firebreaks near electrical lines, oil and gas pipelines.

AN ENGINE THAT'S ALWAYS READY TO GO

The engine of the FAE PT400 guarantees top-level performance. The **Cummins L9** inline six-cylinder engine is one of the world's most popular and highly respected engines. Equipped with twin turbochargers with after cooler and Acert technology, the Tier 4 Final/Stage V version of this engine delivers an impressive 380 hp. Efficient, reliable, with superb consumption/power ratio.

Compliance with the **Tier 4 Final / Stage V** standard is guaranteed with the combination of diesel particulate filter (DPF), selective catalytic reduction (SCR) and diesel oxidation catalyst (DOC) technologies.

A combination that maximizes uptime and requires minimal maintenance over time, achieved by passive regeneration that does not require interrupting the work.

The generous 7-liter displacement and a cooling system designed specifically for the FAE PT400 ensure that both configurations can offer peak performance in both heavy-duty applications and when working in tropical climates.

The simple, uncluttered **internal layout** is synonymous of reliability

Optimized airflow for working in extreme conditions

Easy access to **filters** makes maintenance quick and easy

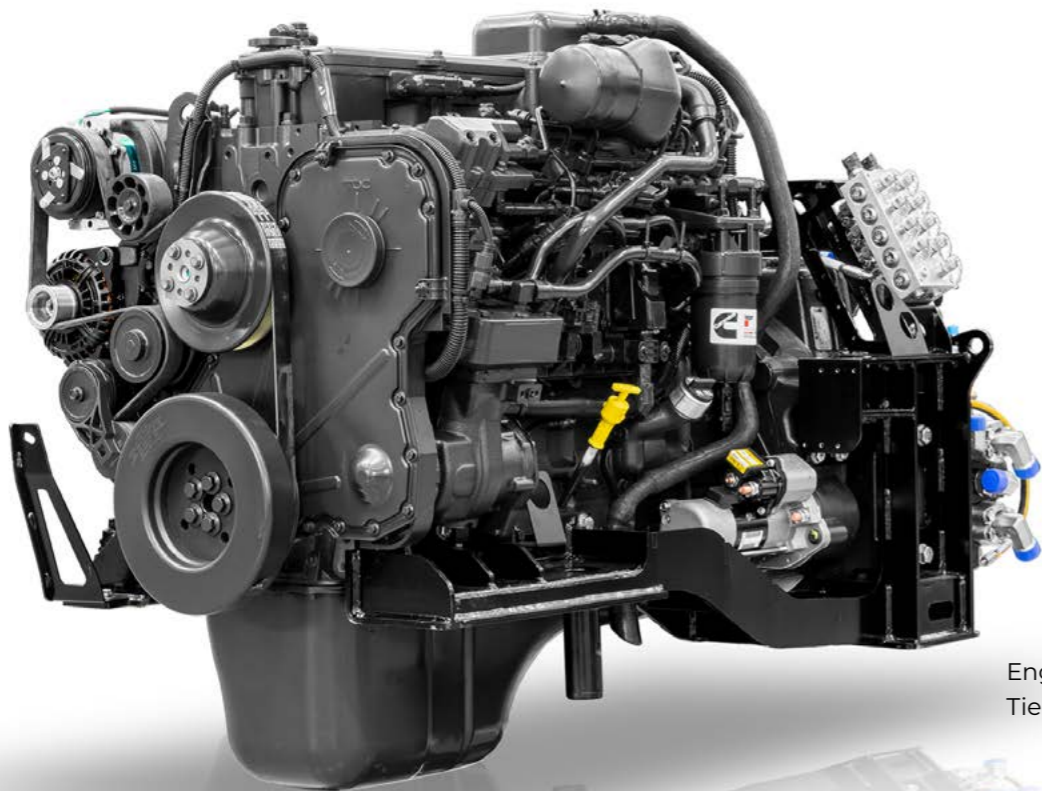

Engine Cummins L9
Tier 4 Final / Stage V

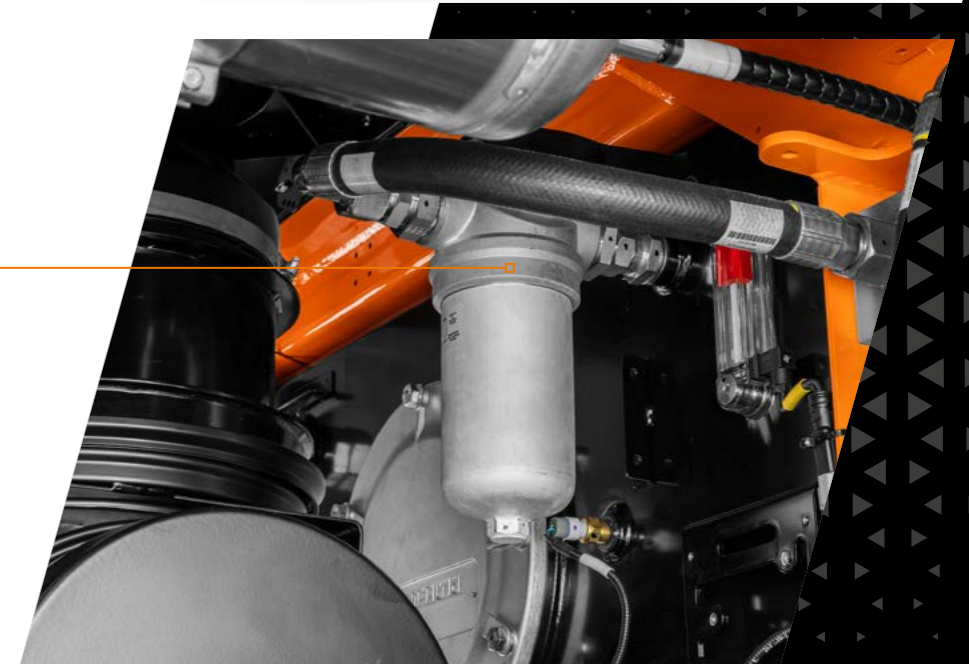
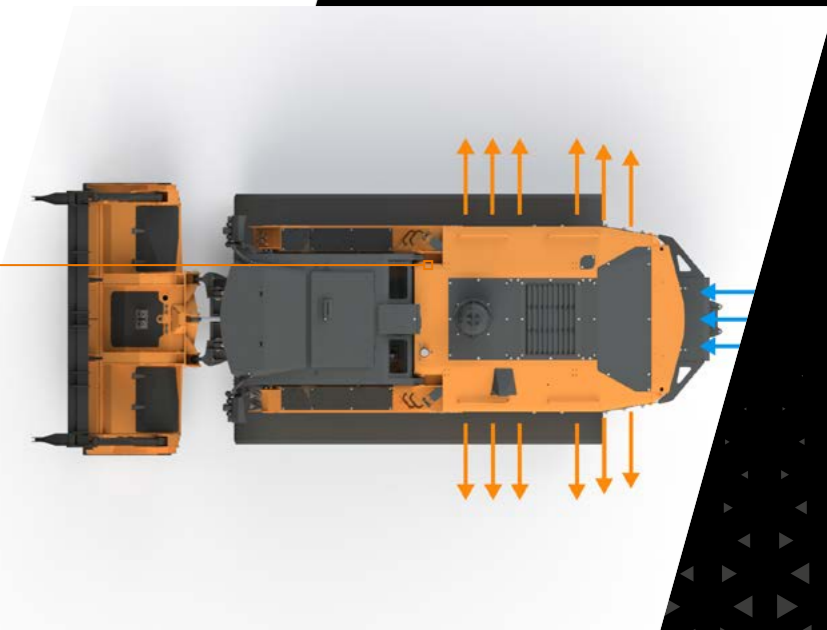

EFFICIENT, RELIABLE TRANSMISSION.

The transmissions designed for the FAE PT400 are based on two fundamental concepts: technology and integration. **Electronically-controlled pumps and sensors and a dedicated control unit**, working together to deliver maximum performance. The systems are designed to enable the Cummins L9 engine to operate at optimal rpms at all times.

The FAE PT400's **hydrostatic transmission** also serves to dampen operating loads. This ensures that the carrier and its key components are subjected to less stress, reducing wear and tear. The end result is greater durability than a mechanical transmission.

An added benefit of the FAE PT400's hydrostatic transmission is that they can accommodate a **wide variety of dedicated FAE equipment** such as forestry mulchers, stump cutters, stump grinders and dozer blades.

The PT400 can be equipped with **Active Power Management**, an intelligent FAE system that automatically manages vehicle advancement in relation to the force absorbed by the rotor. This feature also helps the machine automatically adapt to the contour of the terrain. The operator can now concentrate on the job at hand, for higher productivity.



Diagram of the FAE PT400 **hydrostatic transmission**: simple and effective

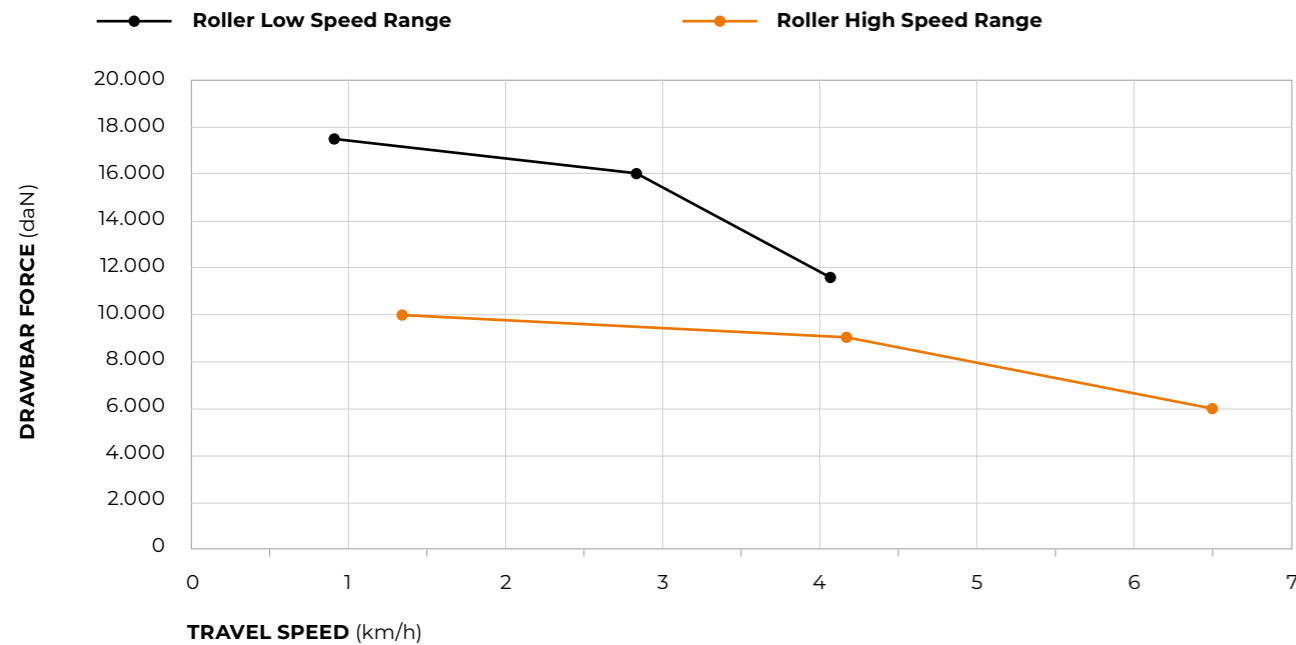
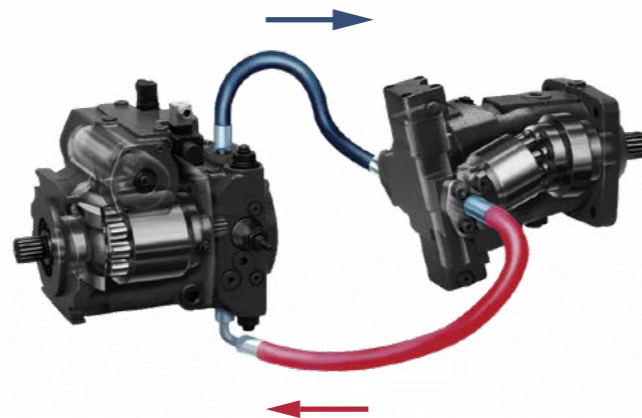

NOTE: Usable force will depend upon: machine weight, permitted traction, working duty cycle



- 1 Horn
- 2 High gear selector
- 3 Low gear selector
- 4 Variable gear speed increase / decrease
- 5 Windshield wipers / Pneumatic cleaning system activation

The traction force can be controlled precisely and safely with the **trackball on the joystick**

HEAVY DUTY UNDERCARRIAGE.

The FAE PT400 undercarriage is designed to provide maximum operating performance and reliability, even in the most demanding conditions.

Prime quality **Berco components**. Chains with lifetime lubrication offer longer life than conventional chains as well as greater operator comfort. Solid, reliable dozer-type rollers. Oscillating undercarriage technology for superior traction and comfort. Two options available for roller guards to better adapt to different working environments.

Conventional geometry ensures a **low center of gravity** and provides **optimal contact between chain and drive wheel**. Two fundamental elements for the best possible work, even on slopes. The FAE PT400 wheelbase also extends the area over which the load is distributed, which means **lower specific pressure against the ground**.

The frames of the PT400 undercarriage are designed to withstand major stresses and make maintenance easier.

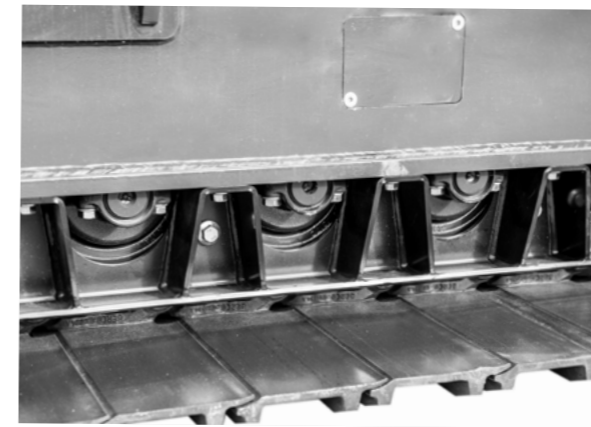

Solid **rock guards**

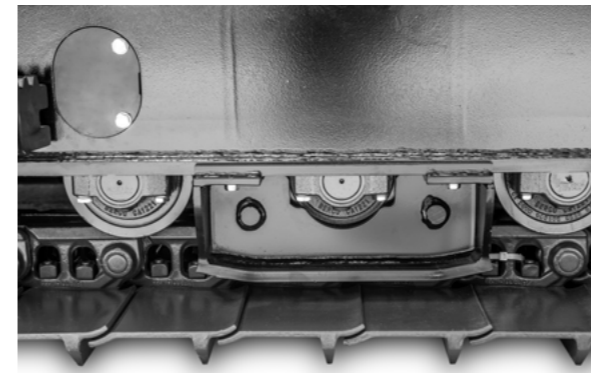

Chain **guide**

3 **slide** configurations to adapt to any terrain



Double grouser - **800 mm (Option)**



Single grouser - **660 mm (Standard)**



Single grouser - **800 mm (Option)**



Oscillating **undercarriage technology** boosts grip and comfort

A SERIOUSLY COMFORTABLE CAB.

The cab of the FAE PT400 is designed for those who work in extreme conditions. It is ergonomic, soundproof and guarantees optimal visibility, making it an industry benchmark.

Joysticks built into the pneumatic suspension seat allow for easy, precise operation of the PT400. The controls on the side console are distributed to make them user friendly, and the 7" color display keeps the essential carrier parameters in view at all times.

ROPS/FOPS/OPS certification meets the highest standards of operator safety, even in the most demanding applications. The air conditioning system vents located throughout the cabin provide all the comfort the operator needs, in hot or cold weather. An optional **cabin pressurization system** is also available.

The large, **12-mm thick, impact and scratch-resistant Lexan™ windows** provide excellent visibility. Powerful LED work lights offer broad coverage, ensuring precise, safe work in all conditions.

Each and every item in the cabin has been carefully **designed with ergonomics in mind.**



7" electronic color **display**

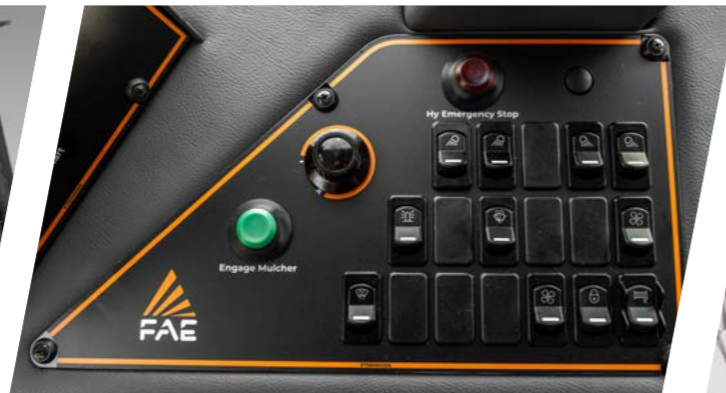

User-friendly side **console**



Powerful **air conditioning system**

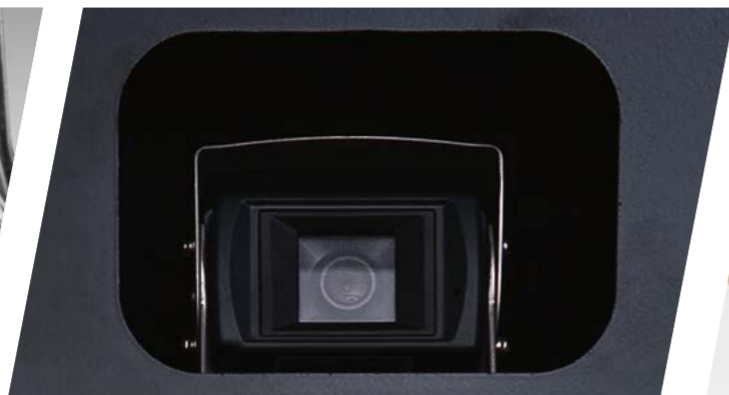

Optional **rear view camera**



EASY TO USE, EASY TO MAINTAIN.

Everything about the FAE PT400 is designed to be effortless, from operation to maintenance.

Access to the engine compartment is easier with the **large doors with shock-resistant closures**. The compartment is also protected by micro-perforated plates that prevent material from getting

inside. Accessing the filters, tanks and hydraulic system components is easier with the large engine compartment and its organized interior layout. The large doors and **tilting cab** ensure easy maintenance, whether checking fluid levels or running routine checks and more. A **powerful air compressor comes standard for daily cleaning**. In addition, a **heavy**

duty kit can be installed to add an extra degree of air filtration and extend the life of the engine air filter.

The PT400's efficient cooling system comes standard with a **radiator combined with anti-clogging fins** specially designed by FAE. It can also be integrated with reversible, proportional fans that ensure peak

performance and maximize radiator core cleanliness. In fact, the fans are regulated by the machine's control unit, adjusting the tilt of the blades according to the operating temperature. This optimizes airflow and also saves fuel.



Level control is simplified by an organized layout (1)



The **large rear doors** have safety catches (2)



Fluid level indicators are clear and easy to locate (3)

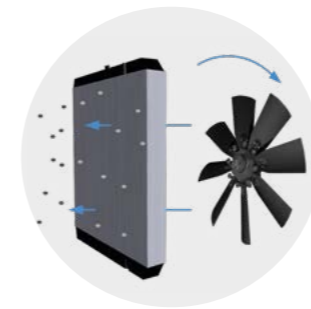

A **reversible fan** maximizes radiator efficiency (4)



Couplings make it possible to quickly **drain fluids** without leaks (5)



The **air compressor** makes daily cleaning easier (6)

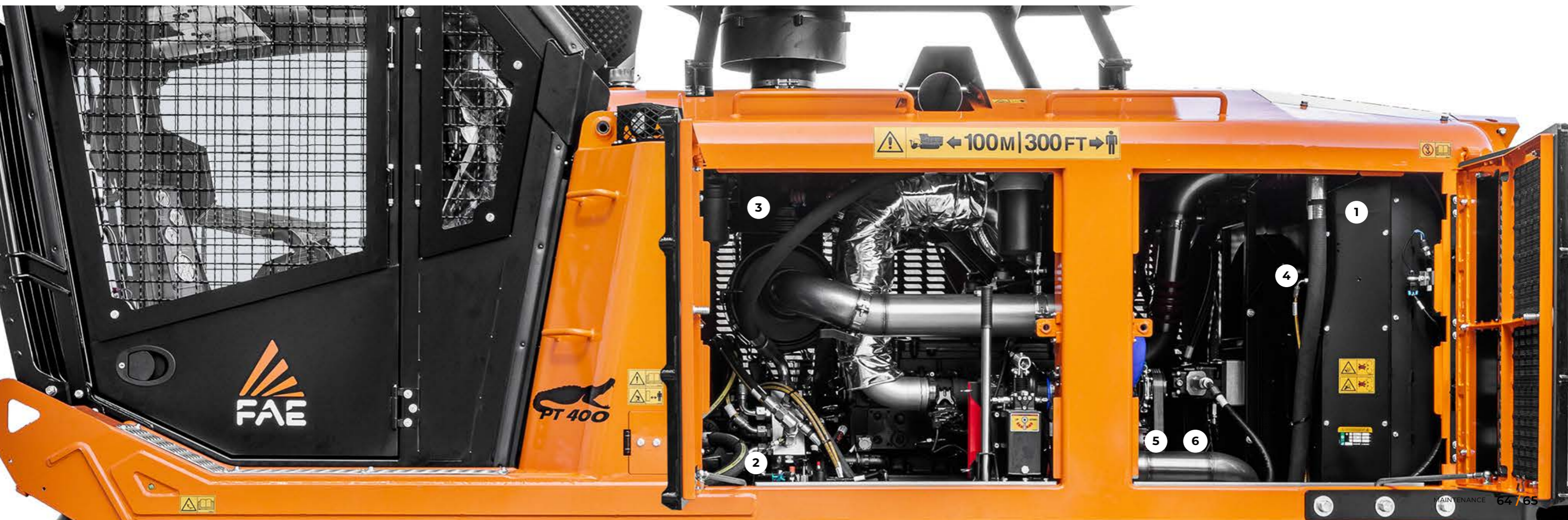

FORESTRY MULCHERS FOR SPECIAL VEHICLES - PT

200/U/PT

Heavy duty hydraulic mulcher with Sonic technology.

The 200/U/PT combines compact maneuverability with the performance of larger machines. It is strong and highly productive for mulching bushes, branches and trees up to 35 cm in diameter.



Sonic System



Ø 35 cm max



FORESTRY MULCHERS FOR SPECIAL VEHICLES - PT

300/U/PT

Heavy duty hydraulic mulcher with Sonic technology.

The 300/U/PT mulcher is highly productive, strong, and lightweight, with a fixed-teeth rotor that lets it mulch plants and trunks up to 40 cm in diameter.



Sonic System



Ø 40 cm max

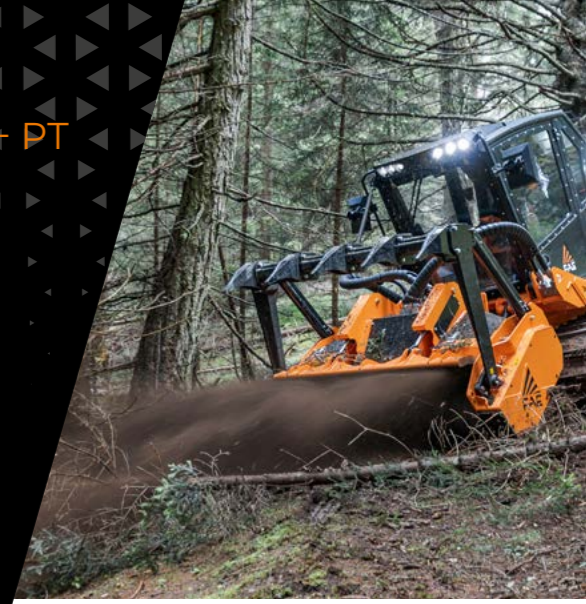

MODEL	200/U/SONIC/PT300/ PT400-200	200/U/SONIC/PT300/ PT400-210	200/U/SONIC/PT300/ PT400-225
Head type	Mulcher	Mulcher	Mulcher
Working width (mm)	2064	2148	2304
Total width (mm)	2464	2548	2704
Weight (kg)	2440	2510	2600
Rotor diameter (mm)	500	500	500
Max shredding diameter (mm)	350	350	350
No. teeth type C/3+C/3/SS	42+2	44+2	46+2

Data refers to machine as standard. The technical data in this catalogue may be altered without prior notice.

MODEL	300/U/SONIC/PT300/PT400-200	300/U/SONIC/PT400-225
Head type	Mulcher	Mulcher
Working width (mm)	2064	2304
Total width (mm)	2544	2784
Weight with C-type (kg)	3500	3850
Weight with B-type (kg)	3550	-
Rotor diameter (mm)	590	590
Max shredding diameter (mm)	400	400
No. teeth type B/3 + C/3/SS	72+2	-
type C/3+C/3/SS	44+2	50+2

Data refers to machine as standard. The technical data in this catalogue may be altered without prior notice.

ROTOR TYPE C



ROTOR TYPE BL



ROTOR TYPE I



ROTOR TYPE B



ROTOR TYPE C

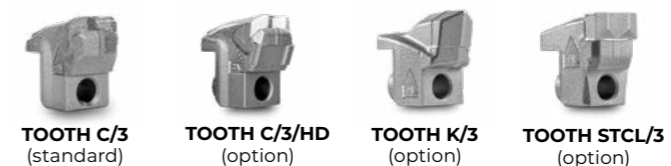

STUMP CUTTERS FOR SPECIAL VEHICLES - PT

300/SC/PT

Hydraulic stump cutters.

The 300/SC/PT can shred large stumps and roots up to 50 cm in diameter and 100 cm deep. The hydraulic and proportional swing control allows to work on wide surfaces without moving the vehicle.



Ø 50 cm max



Depth 100 cm



FORESTRY TILLERS FOR SPECIAL VEHICLES - PT

200/S/PT

Hydraulic forestry tiller.

The 200/S/PT is lightweight and comes in different widths, making it perfect for different situation. The gear drive lets the rotor work at a slower speed than conventional belt-driven forestry mulchers.



Ø 30 cm max



Depth 30 cm



Hydraulic and proportional swing control

Hydraulic motor with relief valve

Poly Chain belt transmission
optimal power management

Interchangeable protection chains with safely deflects debris
limit the escape of the shredded material

Auxiliary and support blade
for better grinding performance



Dual transmission with side gearbox

180 cc hydraulic motor

Hydraulically controlled hood
to adjust final product size

MODEL	300/SC/PT300/PT400-220
Head type	Stump cutter
Working width max range (mm)	1450
Blade width (mm)	1050
Weight (kg)	2100
Disc rotor diameter (mm)	1020
Disc rotor width (mm)	160
Max working depth (mm)	1000
Max shredding diameter (mm)	500
No. teeth type M/1+M/2+M/3+M/4	24+4+24+4

Data refers to machine as standard. The technical data in this catalogue may be altered without prior notice.

MODEL	200/S/PT300/PT400-200	200/S/PT300/PT400-225	200/S/PT300/PT400-250
Head type	Fresa	Fresa	Fresa
Working width (mm)	2080	2320	2560
Total width (mm)	2352	2662	2902
Weight (kg)	2950	3162	3400
Rotor diameter (mm)	600	600	300
Max working depth (mm)	300	300	300
Max shredding diameter (mm)	300	300	600
No. teeth type B/3+C/3/SS	74+4	82+4	82+4

Data refers to machine as standard. The technical data in this catalogue may be altered without prior notice.

ROTOR DISC



TOOTH M/3
(standard)



TOOTH M/1
(standard)



TOOTH M/4
(standard)



TOOTH M/2
(standard)

ROTOR TYPE B



TOOTH B/3
(standard)



TOOTH B/3/HD
(option)



TOOTH G/3
(option)



TOOTH G/3/HD
(option)



TOOTH C/3/SS
(side scraper)

MULTITASKS FOR SPECIAL VEHICLES - PT

SFM/PT

Mulcher, stone crusher and cutter for the PT400.

The SFM/PT is a multitask attachment for the FAE PT400 tracked carrier, which can shred wood, crush stones and cut stumps or roots, all in one head.



Ø 20 cm max (Stones)
Ø 35 cm max (Trees)
Ø 45 cm max (Stump)



Depth 30 cm



BLADE FOR SPECIAL VEHICLES - PT

Dozer Blade PT

Eight-way dozer blade with heavy-duty structure and 2400 mm width. Designed for rough and finish grading in dirt and leveling, the FAE Dozer blade features interchangeable Hardox® wear-resistant cutting edges, a guarantee of resistance and reliability. Thanks to the hydraulic control of the movements, the blade can reach 15° of angle and 10° of side-tilt in both directions. The hydraulic system is equipped with relief valves to protect it from overload in the angle and side-tilt movements.



Interchangeable wear-resistant Hardox® plates

Hydraulically hood to adjust final product size

Transmission with side gearbox which maximizes power to the rotor

Adjustable Hardox® counter blade

MODEL	SFM/PT300/PT400-225	
Head type	Multitask	
Working width (mm)	2310	
Total width (mm)	2620	
Weight (kg)	4215	
Max working depth (mm)	300	
Max shredding diameter (mm)	Stones	200
	Trees	350
	Stumps	450
Rotor diameter (mm)	670	
No. teeth type F/3 + STC/3/FP+BAZ	58+6+4	

Data refers to machine as standard. The technical data in this catalogue may be altered without prior notice.

ROTOR TYPE F



TOOTH F/3 (standard)



TOOTH STC/3/FP (side scraper)



TOOTH BAZ (side scraper)

MOVEMENTS RANGE

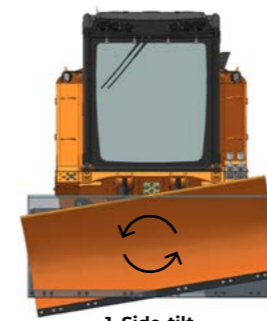

1. Side-tilt

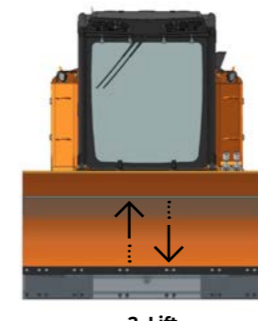

2. Lift

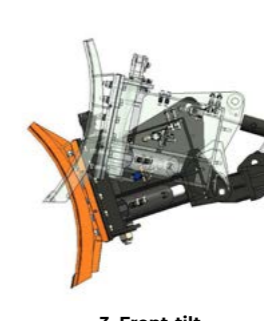

3. Front-tilt



4. Angle

The 8-way movement allows side-tilting (1), lifting/lowering (2), front-tilting (3) and angle (4) the blade, all from the vehicle cabin or from the remote control.

TECHNICAL SPECIFICATIONS

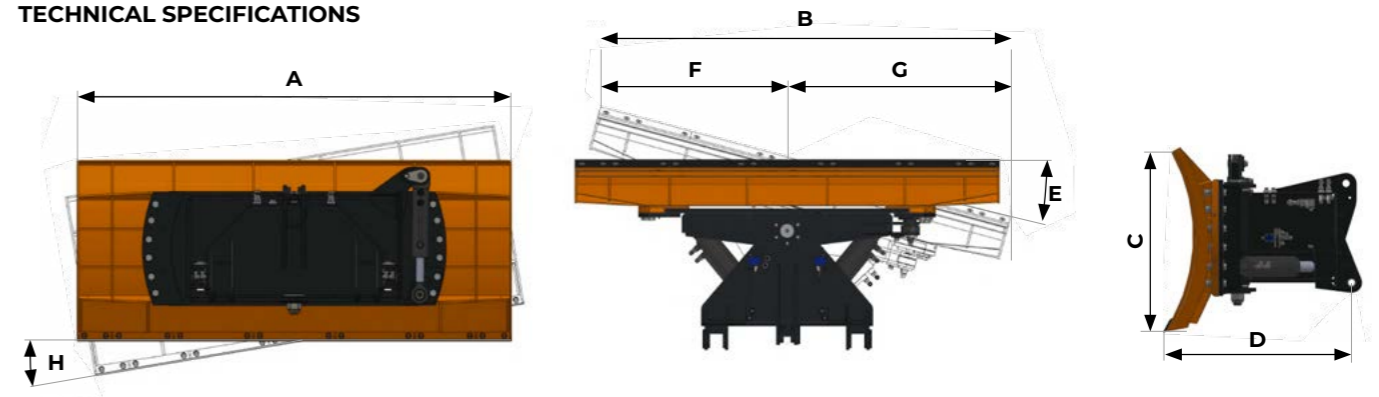

MODEL	Lama Dozer PT300/PT400-240
A. Blade width (mm)	2400
B. Width fully angled (mm)	2320
C. Moldboard height (mm)	970
D. Overall length with attachment plate (mm)	1020
E. Blade angle	±15°
F. Center blade-left edge distance (when fully angled) (mm)	1055
G. Center blade-right edge distance (when fully angled) (mm)	1265
H. Blade side-tilt	±10°
Weight (kg)	1400
Moldboard thickness (mm)	15

Data refers to machine as standard. The technical data in this catalogue may be altered without prior notice.

PT400

TECHNICAL SPECIFICATIONS.



380 hp | CUMMINS L9 ENGINE | Tier 4 Final / Stage V

STANDARD EQUIPMENT

CUMMINS L9 turbocharged and aftercooled engine	12-mm Lexan cabin windshield
DOC/DPF/SCR after-treatment system	Comfort driver's seat (heated and air suspended)
Combined aluminium cooler with anti-clogging fins	Double emergency exit and roof hatch handle to open from the outside
Hydrostatic tracks transmission	Ergonomic joysticks
Oscillating undercarriage	Heating and air conditioning system
660-mm single-grouser steel pads, lubricated chain, dozer-roller version	Cabin dust filtration
Hydrostatic attachment transmission	7" LCD color display
SONIC system	Multimedia - Bluetooth radio
Oscillating style H-frame	Air compressor system
ROPS/FOPS/OPS-approved cabin	LED working lights
Hydraulic control kit for winch and push frame	

DIMENSIONS

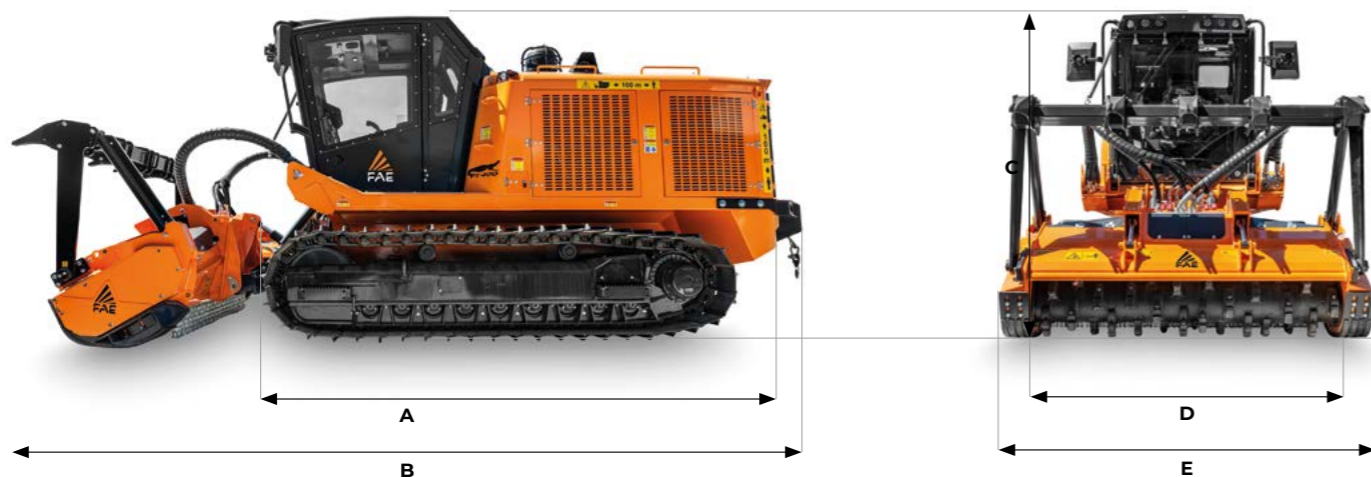

- A** Overall length without attachment 5130 mm
- B** Transport length with 300/U/PT attachment on ground and winch 7190 mm
- C** Max height 2813 mm
- D** Overall track width 2360 mm (with 660 mm pads)
- E** See attachments table

PT400 Tier 4 Final / Stage V

Engine Gross Power	380 hp
Engine Emission	U.S. EPA Tier 4 Final / EU Stage V
Travel Pumps	2 - EP control - 78 cc - Danfoss
Travel Motors	2 - HY control - 80 cc - Danfoss
Max Travel Pressure	420 Bar
Attachment Pump	1 - EP control - 165 cc - Danfoss
Max Mulcher Pressure	350 Bar
Hydraulic Oil Tank Capacity	320 L
Fuel Tank Capacity	340 L
DEF AdBlue® Tank	56 L
Track Chain	171 mm Pitch - lubricated - Berco (std equipment with 660 mm pads)
Lower Rollers	6 + 6 Single Flange + 3 + 3 Double Flange
Carrier Rollers	2 + 2
Voltage	24 volt
Max Forward Speed	6,5 Km/h
Max Reverse Speed	6,5 Km/h
Gradeability	Continuous vertical 35° (intermittent 45°), Continuous lateral 35°
Operating Weight	12290 Kg (std equipment with 660 mm pads) 12555 Kg (std equipment with 800 mm pads DG)
Ground Pressure	0,32 Kg/cm ² (std equipment / 800 mm pads DG / 300/U/SONIC/PT300/PT400-200)

ATTACHMENT

MODEL	200/U/SONIC/ PT300/PT400-200	200/U/SONIC/ PT300/PT400-210	200/U/SONIC/ PT300/PT400-225	300/U/SONIC/ PT300/PT400-200	300/U/SONIC/ PT400-225
Head type	Mulcher	Mulcher	Mulcher	Mulcher	Mulcher
Working width (mm)	2064	2148	2304	2064	2304
Total width (mm)	2464	2548	2704	2544	2784
Weight (kg)	2440	2510	2600	3500 (C) - 3780 (B)	3850 (C)
Rotor diameter (mm)	500	500	500	590	590
Max shredding diameter (mm)	350	350	350	400	400
No. teeth type B/3 + C/3/SS	-	-	-	72+2	-
type C/3+C/3/SS	42+2	44+2	46+2	44+2	50+2

MODEL	200/S/PT300/ PT400-200	200/S/PT300/ PT400-225	200/S/PT300/ PT400-250	300/SC/PT300/ PT400-220	SFM/PT300/PT400- 225
Head type	Tiller	Tiller	Tiller	Stump cutter	Multitask
Working width (mm)	2080	2320	2560	-	2310
Working width max range (mm)	-	-	-	1450	-
Total width (mm)	2352	2662	2902	1050	2620
Weight (kg)	2950	3162	3400	2100	4215
Rotor diameter (mm)	600	600	600	1020 (Disc rotor)	670
Disc rotor width (mm)	-	-	-	160	-
Max working depth (mm)	300	300	300	1000	300
Max shredding diameter (mm)	300	300	300	500	200 (stones) - 350 (trees) - 450 (stumps)
No. teeth type B/3+C/3/SS	74+4	82+4	96+4	-	-
type M/1+M/2+M/3+M/4	-	-	-	24+4+24+4	-
type F/3+STC/3/FP+BAZ	-	-	-	-	58+6+4

TEETH

200/U/PT	300/U/PT	200/S/PT	300/SC/PT	SFM/PT
ROTOR C	ROTOR C	ROTOR B	ROTOR B	DISC ROTOR
C/3 (standard)	C/3 (standard)	B/3 (standard)	B/3 (standard)	M/1 (standard)
C/3/HD (option)	C/3/HD (option)	B/3/HD (option)	B/3/HD (option)	M/2 (standard)
K/3 (option)	K/3 (option)		G/3 (option)	M/3 (standard)
STCL/3 (option)	STCL/3 (option)		G/3/HD (option)	M/4 (standard)
C/3/SS (side scraper)	C/3/SS (side scraper)	C/3/SS (side scraper)	C/3/SS (side scraper)	
				ROTOR F
				F/3 (standard)
				STC/3/FP (side scraper)
				BAZ (side scraper)

OPTIONS

OPTIONS

Rear winch with 6-t traction force	Chain guide
Canopy	6-mm Lexan cabin windshields
Bio-oil	Reversible and proportional radiator fan
Cabin pressurization system	Heavy-duty filtration system (drainage and ejector kit)
Front cabin grille	Custom color
Air window cleaning system	Engine and hydraulic oil pre-heating system
Visibility Package (LED headlights + back-up camera)	Air shutoff valve
Easy Service package (oil filling pump and service lights)	Automatic fire-extinguishing system
800-mm single-grouser steel pads	Forestry protection kit (cabin side window grilles + engine compartment door protectors)
800-mm double-grouser steel pads	Active Power Management system (Load Control and Floating System)
Roller and drive wheel undercarriage stone guard	



Visibility Package (back-up camera)



Visibility-Paket (LED-Scheinwerfer)

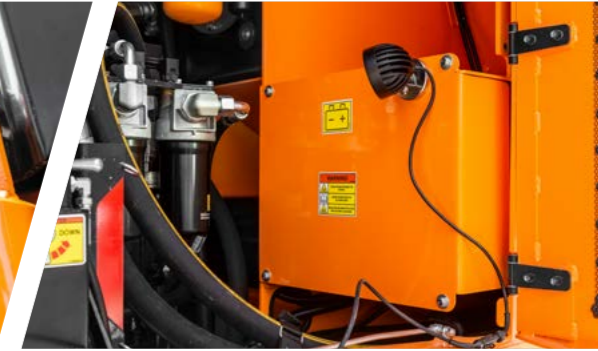

Easy Service package (service light)



Easy Service package (oil filling pump)

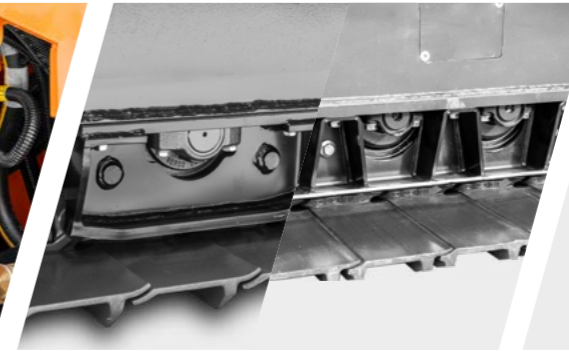

Chain guides - Rock guards



Forestry protection kit (cabin side window grilles + engine compartment door protectors)



Rear winch with 6-t traction force



Canopy



H frame with tilting system

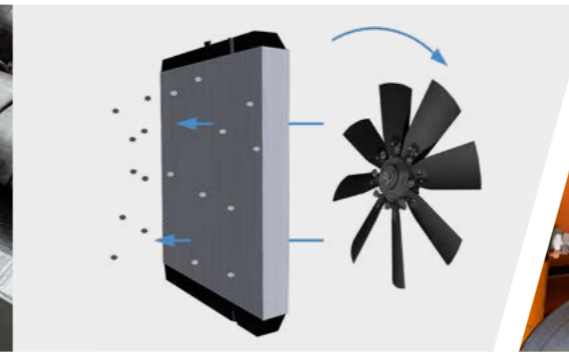

Reversible and proportional radiator fan



Heavy-duty filtration system (ejector)



Heavy-duty filtration system (drainage)



Cabin pressurization system



Front cabin grille



Air window cleaning system



Engine and hydraulic oil pre-heating system

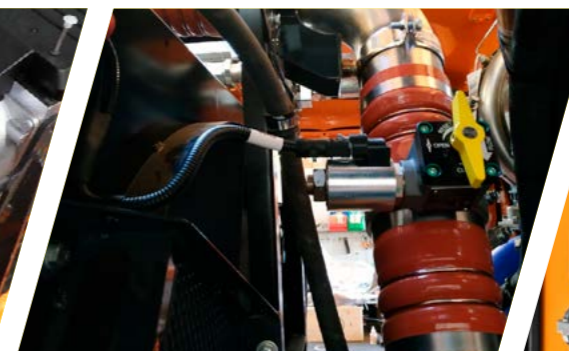

Air shut-off system



Automatic fire-extinguishing system

FAE PT550

THE TRACKED CARRIER FOR BIG CHALLENGES.

The FAE PT550 is the perfect tracked carrier for major work in wooded areas and forests or along oil and gas pipelines. The sturdy construction with oscillating undercarriage can be equipped with forestry mulchers, stump cutters or multitask head for crushing stone and tilling soil. The amazing power of the CAT C13B (CAT C13 Acert engine for Tier 3 - Stage III A version) straight-six engine lets you work on soft, uneven and swampy ground. The hydraulic system guarantees reliability and efficiency. The spacious cab is unrivaled when it comes to comfort, ergonomics and operator safety.

POWERFUL

The strength and reliability of the six-cylinder Caterpillar engine C13B with 536 hp (engine C13 with 475 hp for the Tier 3 / Stage version III A). Always top-notch performance supported by a global service network.

UNSTOPPABLE

Working on vast terrains with soft, uneven or swampy ground is the norm. Longitudinal slopes with a maximum of 45° and transverse slopes with a maximum of 32°. High power and minimum ground pressure of 0.41 kg/cm².

TECHNOLOGICAL

High-tech body and soul. An integrated system developed by FAE to ensure maximum performance. With a network of sensors to monitor key operating parameters, everything can be easily fine-tuned.

COMFORTABLE

Cab designed with total operator comfort and safety in mind. Pressurized Cat. 2 certified ROPS/FOPS/OPS, industry benchmark. High Lexan™ windows. Ergonomic joysticks. Pneumatic seat. 10" touch screen to control all operating functions. 360° camera system and dedicated display.



VERSATILE

Perfect for working in large woods or forests or along oil and gas pipelines. It can be paired with forestry mulchers, stump cutters or multitask head for crushing stones and tilling soil. It can be hooked up to a forestry mulcher or a multitask head for crushing stones and tilling soil, which can also be combined with the Floating System function to ensure the unit always follows the ground's contours closely and the Load Control function for optimal operating power management.

AN ENGINE THAT'S ALWAYS READY TO GO.

The **Caterpillar C13 (CAT C13 Acert engine for Tier 3 - Stage III A version)** six-cylinder engine in the FAE PT550 guarantees strength, reliability and global support. Equipped with a turbocharger with after cooler, the Tier 4 Final/Stage V version of this engine delivers a full 536 hp. Efficient, powerful, with superb consumption/power ratio.

Compliance with the **Tier 4 Final/Stage V** standard is guaranteed with the combination of diesel particulate

filter (DPF), selective catalytic reduction (SCR) and diesel oxidation catalyst (DOC) technologies. The vehicle is also available in the Tier 3 / Stage III A version, with a power of 475 hp.

The large, 12.5-liter displacement and a cooling system designed specifically for the FAE PT550 ensure that offer peak performance both in heavy-duty applications and when working in tropical climates.

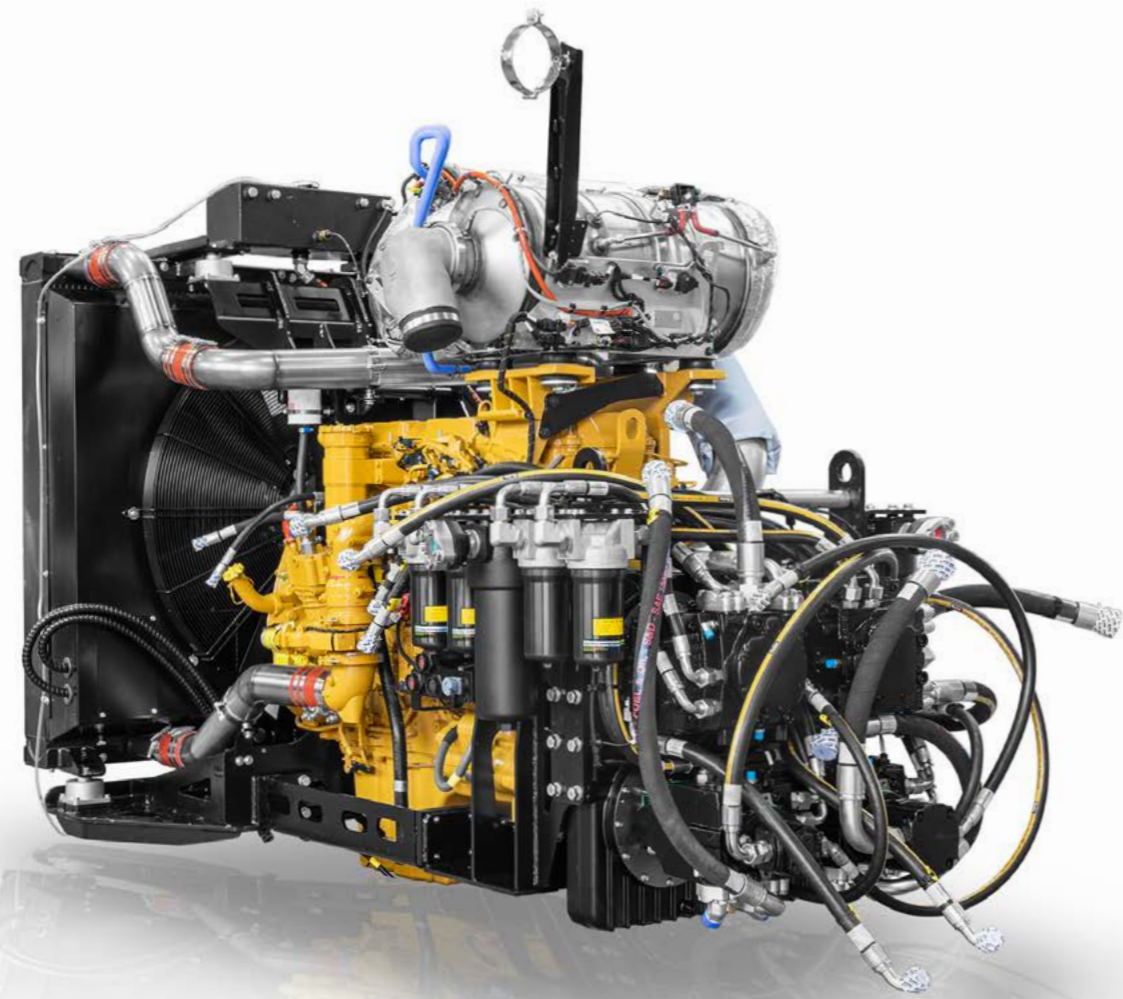

Engine
Tier 4 Final / Stage V

The simple, uncluttered **internal layout** is synonymous of reliability



Optimized airflow for working in extreme conditions

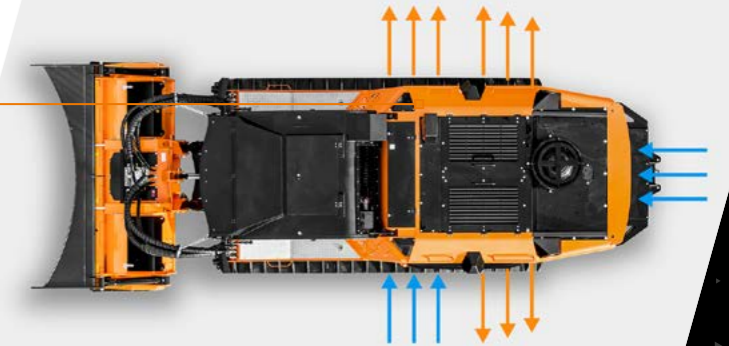

Easy access to **filters** makes maintenance quick and easy



EFFICIENT, RELIABLE TRANSMISSION.

The transmissions designed for the FAE PT550 are based on two fundamental concepts: technology and integration. **Electronically-controlled pumps and sensors and a dedicated control unit**, working together to deliver maximum performance. The systems are designed to enable the CAT C13B and CAT C13 engines to operate at optimal rpms at all times.

The FAE PT550's **hydrostatic transmission** also serves to dampen operating loads. This ensures that the carrier and its key components are subjected to less stress, reducing wear and tear. The end result is greater durability than a mechanical transmission.

The PT550 can be equipped with **Active Power Management**, an intelligent FAE system that automatically manages vehicle advancement in relation to the force absorbed by the rotor. This feature also helps the machine automatically adapt to the contour of the terrain. The operator can now concentrate on the job at hand, for higher productivity.

An added benefit of the FAE PT550's hydrostatic transmission is its ability to accommodate a **wide variety of FAE equipment**: forestry mulchers, stump cutters or multitask head for crushing stone and tilling soil.



Diagram of the FAE PT550 **hydrostatic transmission**: simple and effective

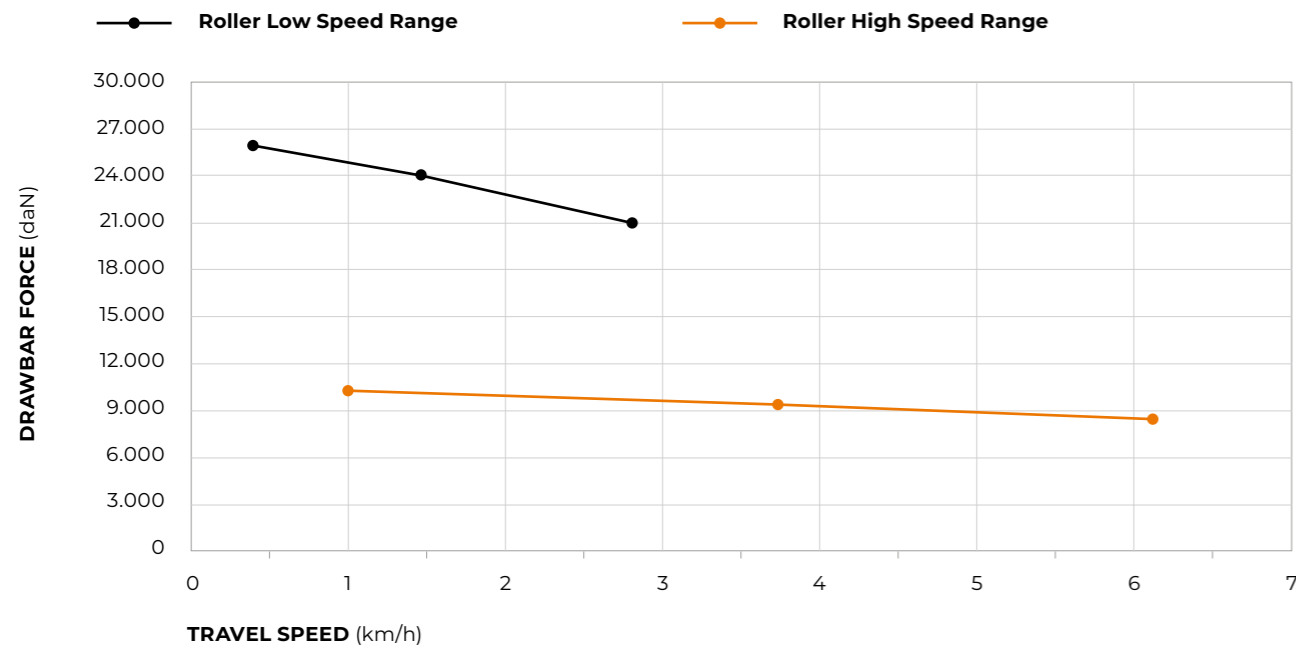
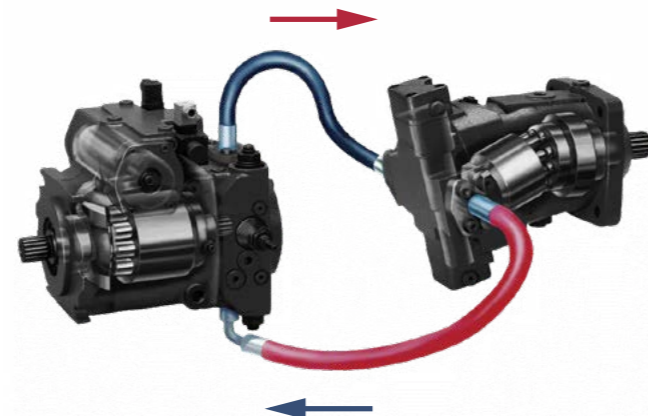

NOTE: Usable force will depend upon: machine weight, permitted traction, working duty cycle



- 1 Windshield wipers / Pneumatic cleaning system activation
- 2 High gear selector
- 3 Low gear selector
- 4 Variable gear speed increase / decrease
- 5 Horn

The traction force can be controlled precisely and safely with the **trackball on the joystick**

HEAVY DUTY UNDERCARRIAGE.

The FAE PT550 undercarriage is designed to provide maximum operating performance and reliability, even in the most demanding conditions.

Prime quality **Berco components**. Chains with lifetime lubrication offer longer life than conventional chains as well as greater operator comfort. Solid, reliable dozer-type rollers. Oscillating undercarriage technology for superior traction and comfort. Two options available for roller guards to better adapt to different working environments.

Conventional geometry ensures a **low center of gravity** and provides **optimal contact between chain and drive wheel**. Two fundamental elements for the best possible work, even on slopes. The FAE PT550 wheelbase also extends the area over which the load is distributed, which means **lower specific pressure against the ground**.

The frames of the undercarriage are designed to withstand major stresses and make maintenance easier.



Solid **rock guards**



Chain **guide**

3 **slide** configurations to adapt to any terrain



Single grouser - **810 mm (Option)**



Single grouser - **600 mm (Standard)**

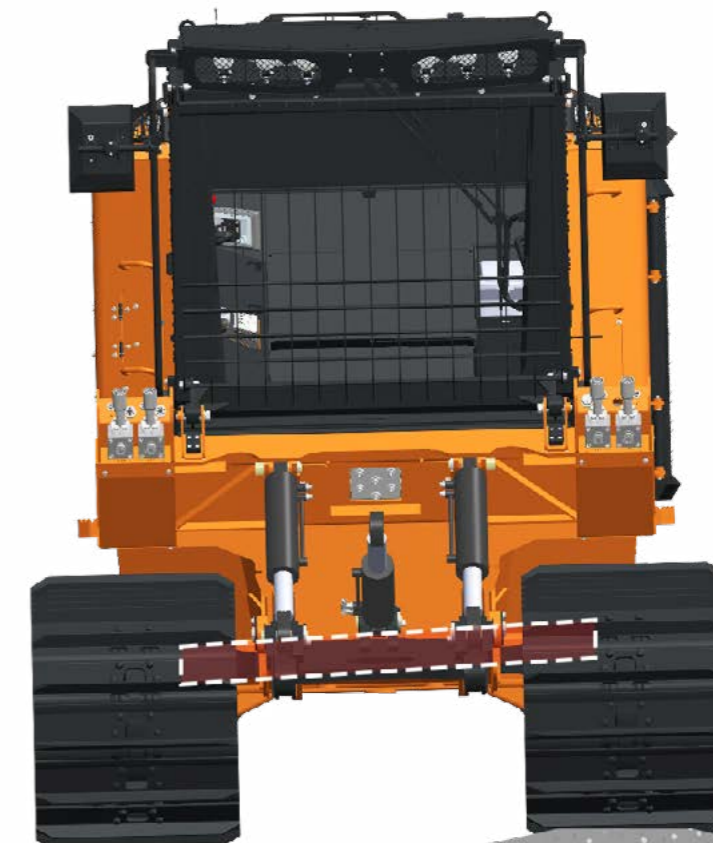

Oscillating **undercarriage technology** boosts grip and comfort

A SERIOUSLY COMFORTABLE CAB.

The cab of the FAE PT550 is designed for those who work in extreme conditions. It is ergonomic, soundproof and guarantees optimal visibility, making it an industry benchmark.

Joysticks built into the pneumatic suspension seat allow for easy, precise operation of the PT550. The controls on the side console are distributed to make them user friendly, and the 10" touchscreen display keeps the essential carrier parameters in view at all times.

ROPS/FOPS/OPS certification meets the highest standards of operator safety, even in the most demanding applications. Cat. 2 certification guarantees optimal internal cab pressure. The air conditioning system vents located throughout the cabin provide all the comfort the operator needs, in hot or cold weather.

The large, 12-mm thick, impact and scratch-resistant **Lexan™ windows** provide excellent visibility. Powerful LED working lights and a 360° camera display system offer broad coverage, ensuring precise, safe work in all conditions.



10" touchscreen **display**



User-friendly side **console**



Powerful **air conditioning system**



Optional **360° viewing camera system**



Each and every item in the cabin has been carefully **designed with ergonomics in mind.**

EASY TO USE, EASY TO MAINTAIN.

Everything about the FAE PT550 is designed to be effortless, from operation to maintenance.

Large doors with shock-resistant closures make accessing the engine compartment easy. The compartment is also protected by micro-perforated plates that prevent material from getting inside.

Accessing the filters, tanks and hydraulic system components is easier with the large engine compartment and its organized interior layout. The large doors and **tilting cab** ensure easy maintenance, whether checking fluid levels or running routine checks and more. A **powerful air compressor comes standard for daily cleaning**. In addition,

a **heavy duty kit** can be installed for an extra degree of air filtration and boosting the life of the engine air filter.

The PT550's efficient cooling system comes standard with a **dedicated diesel engine radiator and a second radiator for the hydraulic system**, built into the door to provide easy access to the engine compartment. Both

radiators feature anti-clogging fins specially designed by FAE. It can also be integrated with reversible, proportional fans that ensure peak performance and maximize radiator core cleanliness. In fact, the fans are regulated by the machine's control unit, adjusting the tilt of the blades according to the operating temperature. This optimizes airflow and also saves fuel.



Level control is simplified by an organized layout (1)



The **large rear doors** have safety catches (2)



Fluid level indicators are clear and easy to locate (3)

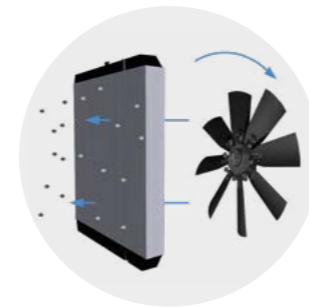

A **reversible fan** maximizes radiator efficiency (4)

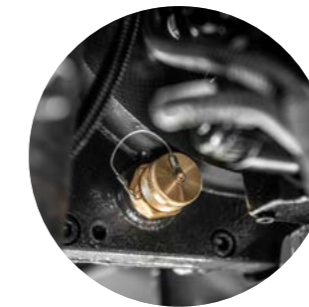

Couplings make it possible to quickly **drain fluids** without leaks (5)



The **air compressor** makes daily cleaning easier (6)



FORESTRY MULCHERS FOR SPECIAL VEHICLES - PT

300/U/PT

Forestry mulcher with Sonic technology.

The 300/U/PT mulcher is highly productive, strong, and lightweight, with a fixed-teeth rotor that lets it mulch plants and trunks up to 40 cm in diameter.



Sonic System



Ø 40 cm max



FORESTRY MULCHERS FOR SPECIAL VEHICLES - PT

500/U/PT

Forestry mulcher with Sonic technology.

The 500/U/PT forestry mulcher is the top of the line for special vehicles, capable of mulching logs up to 50 cm in diameter.



Sistema Sonic



Ø 50 cm max

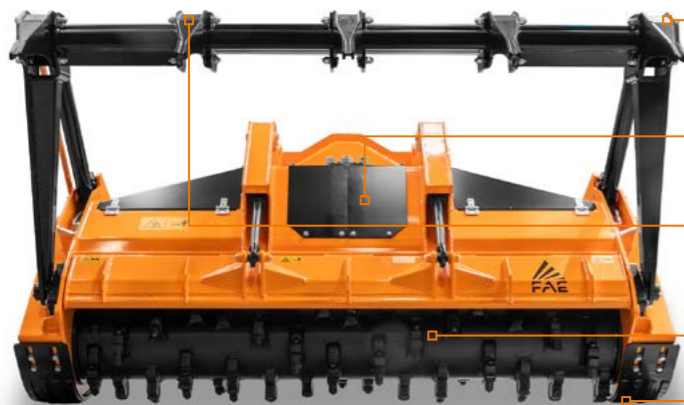
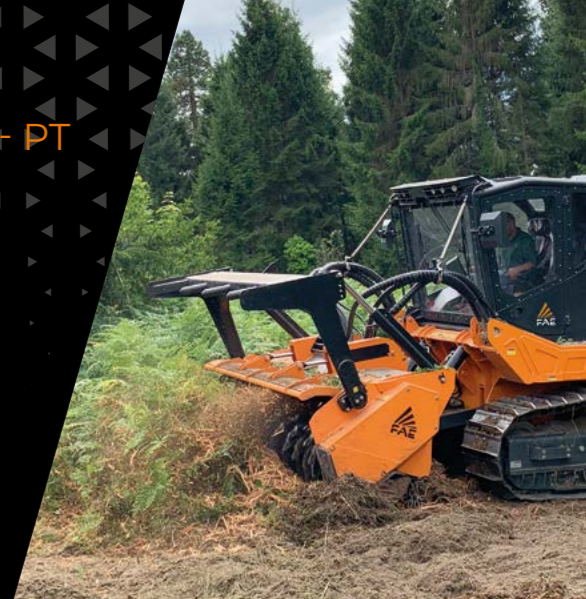

Guard frame hydraulic control (optional)

Hydraulically controlled hood to adjust final product size

Ripper teeth for push frame (optional)

Possibility to have optional rotors and teeth

Adjustable skids



Guard frame hydraulic control (optional)

Hydraulically controlled hood to adjust final product

Possibility to have optional rotors and teeth

Adjustable skids

MODEL	300/U/SONIC/PT550-250
Head type	Mulcher
Working width (mm)	2544
Total width (mm)	3024
Weight (kg)	4145 (C) - 4355 (B)
Rotor diameter (mm)	590
Max shredding diameter (mm)	400
No. teeth type B/3 + C/3/SS	92+2
type C/3+C/3/SS	56+2

Data refers to machine as standard. The technical data in this catalogue may be altered without prior notice.

MODEL	500/U/SONIC/PT550-225	500/U/SONIC/PT550-250
Head type	Mulcher	Mulcher
Working width (mm)	2320	2560
Total width (mm)	2860	3100
Weight (kg)	4710 (C) - 4725 (A)	4960 (C) - 5200 (A)
Rotor diameter (mm)	680	680
Max shredding diameter (mm)	500	500
No. teeth type A/3+MH/3	88+2	96+2
type C/3+C/3/SS	54+2	60+2

Data refers to machine as standard. The technical data in this catalogue may be altered without prior notice.

ROTOR TYPE B



TOOTH B/3 (standard)



TOOTH B/3/HD (option)

ROTOR TYPE C



TOOTH C/3 (standard)



TOOTH C/3/HD (option)



TOOTH K/3 (option)



TOOTH STCL/3 (option)



TOOTH C/3/SS (L/R) (side scraper)

ROTOR TYPE A



TOOTH A/3 (standard)



TOOTH A/3/HD (option)



TOOTH MH/3 (side scraper)

ROTOR TYPE C



TOOTH C/3 (standard)



TOOTH C/3/HD (option)



TOOTH K/3 (option)



TOOTH STCL/3 (option)



TOOTH C/3/SS (L/R) (side scraper)

MULTITASKS FOR SPECIAL VEHICLES - PT

SFH/PT

Stone crusher, forestry tiller and mulcher.

The SFH/PT head can shred logs or stumps and crushes stones up to 40 cm deep. Its double-gear transmission increases shredding power.



Ø 35 cm max (stones)
Ø 45 cm max (trees)
Ø 55 cm max (stump)



Depth 40 cm



Adjustable Hardox® counter blade(R)

Hydraulically controlled hood to adjust final product

Bolt-on interchangeable protection chains

Interchangeable wear-resistant Hardox® plates (R)

Dual transmission with side gearbox converts RPM to Power

MODEL	SFH/PT550-225	SFH/PT550-250
Head type	Multitask	Multitask
Working width (mm)	2320	2560
Total width (mm)	2710	2950
Weight (kg)	5600	5900
Rotor diameter (mm)	900	900
Max working depth (mm)	400	400
Max shredding diameter stones (mm)	350	350
trees (mm)	450	450
stump (mm)	550	550
No. teeth type G/3 - STC/FP - STC/3/FP	60+4+6	66+4+6

Data refers to machine as standard. The technical data in this catalogue may be altered without prior notice.

ROTOR TYPE G



TOOTH G/3 (standard)



TOOTH G/3/HD (option)



TOOTH STC/3/FP (side scraper)



TOOTH STC/FP (side scraper)

PT550

TECHNICAL SPECIFICATIONS.



536 hp | Tier 4 Final / Stage V
475 hp | Tier 3 / Stage III A

STANDARD EQUIPMENT

DOC/DPF/SCR after-treatment system	Comfort driver's seat (heated and air suspended)
CAT C13 Acert turbocharged and after-cooled engine	Ergonomic joysticks
CAT C13 B Acert turbocharged and after-cooled engine	Heating and air conditioning system
Hydrostatic transmission	12-mm Lexan cabin windshields
Hydrostatic transmission attachments	Cabin dust filtration
Fixed H frame with pins	10" touch screen LCD display
Oscillating undercarriage	Multimedia - Bluetooth radio
600-mm single-grouser steel pads, lubricated chain, dozer-roller version	LED working lights
Aluminum engine cooler with anti-clogging fins	Air compressor system
Aluminum hydraulic oil cooler with anti-clogging fins	Air shutoff valve
Cat. 2 ROPS/FOPS/OPS certified pressurized cabin	Sonic System
Heated and refrigerated compartment with cup holders	

DIMENSIONS

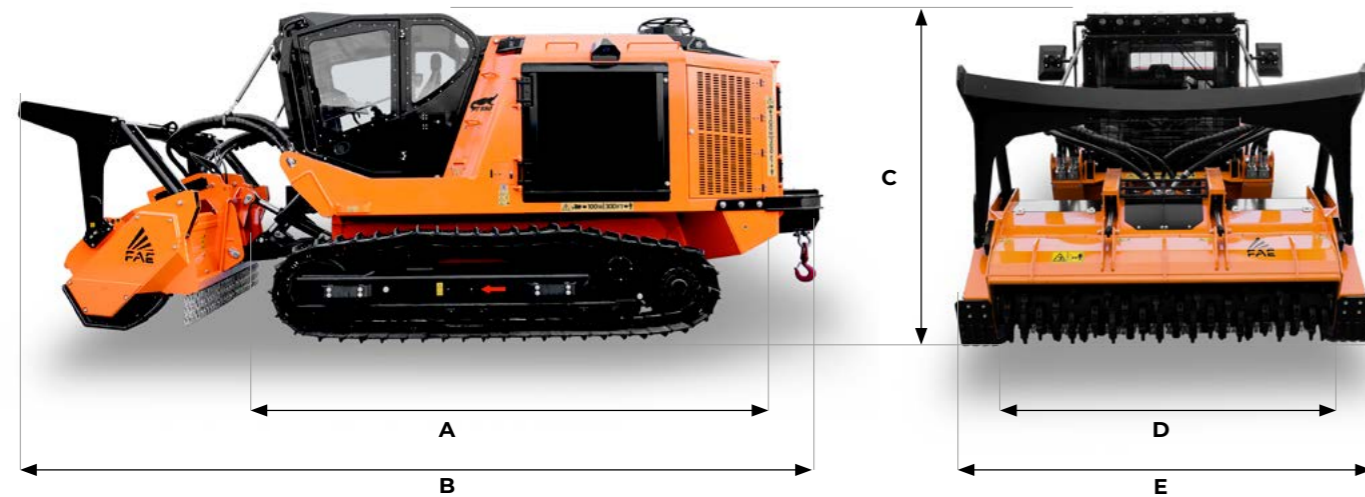

A Overall length without attachment	5776 mm	C Max height	3300 mm
B Transport length with 300/U/PT attachment on ground and winch	8093 mm	D Overall track width	2550 mm (with 600 mm pads)
		E See attachments table	

PT550 Tier 3 / Stage III A

PT550 Tier 4 Final / Stage V

Engine Gross Power	475 hp	536 hp
Engine Emission	U.S. EPA Tier 3 / EU Stage III A	U.S. EPA Tier 4 Final / EU Stage V
Travel Pumps	2 - EP control - 100 cc - Danfoss	2 - EP control - 100 cc - Danfoss
Travel Motors	2 - HY control - 160 cc - Danfoss	2 - HY control - 160 cc - Danfoss
Max Travel Pressure	420 Bar	420 Bar
Attachment Pump	2 - EP control - 130 cc - Danfoss	2 - EP control - 147 cc - Danfoss
Max Mulcher Pressure	350 Bar	350 Bar
Hydraulic Oil Tank Capacity	480 L	480 L
Fuel Tank Capacity	720 L	720 L
DEF AdBlue® Tank	-	70 L
Track Chain	190 mm pitch - lubricated - Berco (std equipment with 600 mm pads)	190 mm pitch - lubricated - Berco (std equipment with 600 mm pads)
Lower Rollers	6 + 6 Single Flange + 3 + 3 Double Flange	6 + 6 Single Flange + 3 + 3 Double Flange
Carrier Rollers	3 + 3	3 + 3
Voltage	24 volt	24 volt
Max Forward Speed	6 Km/h	6 Km/h
Max Reverse Speed	6 Km/h	6 Km/h
Gradeability	Vertical continuous 35° (intermittent 45°), Lateral continuous 32°	Vertical continuous 35° (intermittent 45°), Lateral continuous 32°
Operating Weight	19800 Kg (std equipment with 600 mm pads) 20360 Kg (std equipment with 810 mm pads)	20200 Kg (std equipment with 600 mm pads) 20760 Kg (std equipment with 810 mm pads)
Ground Pressure	0,40 Kg/cm² (std equipment / 810 mm pads / 300/U/SO-NIC/PT550-250)	0,41 Kg/cm² (std equipment / 810 mm pads / 300/U/SO-NIC/PT550-250)

ATTACHMENT

MODEL	300/U/SONIC/PT550-250	500/U/SONIC/PT550-225	500/U/SONIC/PT550-250
Head type	Mulcher	Mulcher	Mulcher
Working width (mm)	2544	2320	2560
Total width (mm)	3024	2860	3100
Weight (kg)	4145 (C) - 4355 (B)	4710 (C) - 4725 (A)	4960 (C) - 5200 (A)
Rotor diameter (mm)	590	680	680
Max shredding diameter (mm)	400	500	500
No. teeth type A/3+MH/3	-	88+2	96+2
type B/3 + C/3/SS	92+2	-	-
type C/3+C/3/SS	56+2	54+2	60+2

MODEL

SFH/PT550-225

SFH/PT550-250

MODEL	SFH/PT550-225	SFH/PT550-250
Head type	Multitask	Multitask
Working width (mm)	2320	2560
Total width (mm)	2710	2950
Weight (kg)	5600	5900
Rotor diameter (mm)	900	900
Max working depth (mm)	400	400
Max shredding diameter stones (mm)	350	350
trees (mm)	450	450
stump (mm)	550	550
No. teeth type G/3 - STC/FP - STC/3/FP	60+4+6	66+4+6

TEETH

300/U/PT				500/U/PT		SFH/PT	
ROTOR C	ROTOR G	ROTOR STONES RESISTANT	ROTOR B	ROTOR C	ROTOR STONES RESISTANT	ROTOR A	ROTOR G
C/3 (standard)	G/3 (standard)	STC/3 (standard)	B/3 (standard)	C/3 (standard)	STC/3 (standard)	A/3 (standard)	G/3 (standard)
C/3/HD (option)	G/3/HD (option)	STC/3/HD (option)	B/3/HD (option)	C/3/HD (option)	STC/3/HD (option)	A/3/HD (standard)	G/3/HD (option)
K/3 (option)		STC/3/FP (option)		K/3 (option)	STC/3/FP (option)		
STCL/3 (option)				STCL/3 (option)			
C/3/SS (side scraper)	STC/3/HD (side scraper)	STC/3/FP (side scraper)	C/3/SS (side scraper)	C/3/SS (side scraper)	STC/3/FP (side scraper)	MH/3 (side scraper)	STC/3/FP - STC/FP (side scraper)

Data refers to machine as standard. The technical data in this catalogue may be altered without prior notice.

OPTIONS

OPTIONS

Rear winch with 13-t traction force	Chain guide
Front cabin grille	Roller and drive wheel stone guard
Visibility Package (LED headlights + 360° cameras)	Reversible and proportional radiator fans
Air window cleaning system	Filtration with heavy-duty ejector
Pre-heating system	Bio-oil
Additional LED headlights	Custom color
810-mm single-rib steel slides	Active Power Management system (Load Control and Floating System)
Easy Service package (oil filling pump and service lights)	



Easy Service package (oil filling pump)

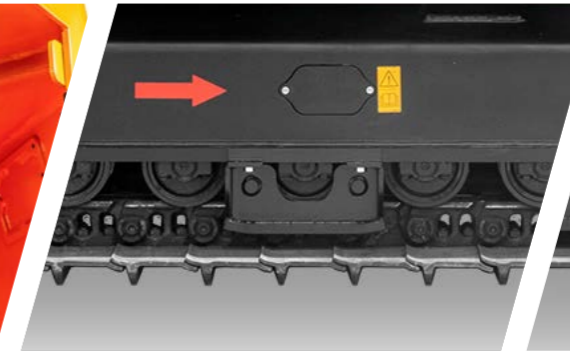

Chain guide



Roller and drive wheel stone guard

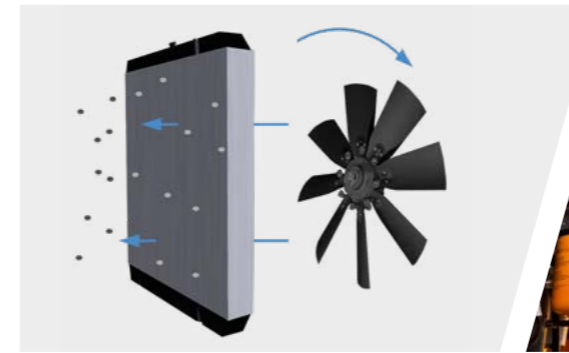

Proportional and reversible fan system with hydraulic control



Filtration with heavy-duty ejector



Pre-heating system



Rear winch with 13-t traction force



Front cabin grille



Air window cleaning system



810-mm single-grouser steel pads



Visibility Package (360° cameras)



Visibility Package (LED headlights)



Easy Service package (service light)

ALWAYS BY
YOUR SIDE
TO **MAKE THE
DIFFERENCE**



